

RD

HELICAL GEARBOXES

two and three gear stages
foot-, flange- and foot/flange-version



CONTENTS



Description	2-4
Symbols	5
Modular system	6-7
Flexible coupling G	8
Flexible coupling selection	9
IEC Flanges & coupling	10
NEMA Flanges & coupling	11
Gearbox & Motor designation	12
VARsize electronic catalogue	13
Mounting positions	14
Service factors	15-16
External loads	17
Selection tables	
Versions	18
Thermal power	19
FRD - SRD - RD	20-26
MRD	27-42
Dimensions	
IEC Motors	43
RD 02-03	44
RD 12-13	45
RD 22-23	46
RD 32-33	47
RD 42-43	48
RD 52-53	49
RD 62-63	50
General information	
Rotation and Component parts	51
Electric motor standards	52
ATEX summing-up	53-55
Operation and Maintenance	56

RD Gearboxes

Description

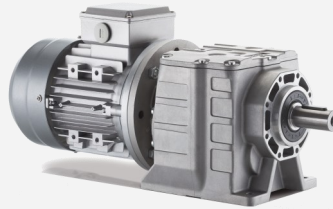

The helical gearboxes Series RD feature a one-piece cast housing complete with inner support to accommodate 2 or 3 gear stages into the same casing.

Manufactured to latest ISO engineering design specifications the housing is checked by computer-aided structural analysis for deflection and stress distribution.

Significant strains caused by the effects of torque and external loads do not deflect the monolithic rib work of the housing, which significantly improves the integrity of the sealed surfaces.

The RD Series is manufactured in B3 foot-mounted configuration.

They can be easily converted to a flange mounting by fitting of the appropriate additional adaptor flange.

Single-setup machining on state-of-the-art CNC production lines, the most recent calculation techniques and process controls give superior operational reliability, maximum output torques, high overhung and thrust load capacity, and long working lifetime.

IEC or NEMA motors are easily mounted by fitting interchangeable bolted flanges and elastic couplings.

The elastic coupling, built-in inside the gearbox body, does not affect any dimensional length increase of the gearbox.

Directive ATEX

The gearboxes VARVEL-ATEX, supplied on demand, are designed and manufactured according to Directive 94/9/CE "ATEX" and therefore, they are qualified for installation in potentially explosive atmospheres:

- Zones of Group II,
- Category 2 (or 3),
- Explosion hazard with gas presence (Zone 1 or 2),
- Explosion hazard with combustible dust presence (Zone 21 or 22).

See detailed information at pages 86, 87.

The units VARVEL-ATEX are identified by the additional marking:

 II 2 GD ck IP66 (T_{max}=135 °C

Gearboxes RD

Description

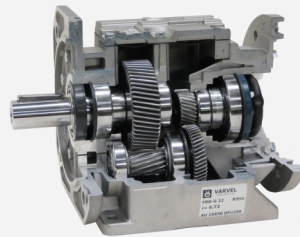

	Helical gearboxes, Series RD
Multipurpose Housing	Foot & Foot/Flange mountings One housing for 2- & 3-stages
Housing & Covers	Aluminium die cast (5 sizes) Grey cast iron (2sizes).
Input	IEC and NEMA motor adapters with universal flexible coupling, or bore and keyway fitting.
Gearing	Alloy steel Case hardened Profile ground or shaved.
Oil seals	NBR - Nitrile Butadiene Rubber as standard, Viton and Silicone on request.
Bearings	Ball or roller types according to sizes and technical requirements.
Output	Solid shafts, metric and imperial on demand
Lubrication	Synthetic long-life oil Grade ISO VG 320 No oil/vent plugs In-house filling

RD Gearboxes

Description

	General Specifications
Range	7 sizes 28 ratios in 2 and 3 stages 2300 Nm max. output torque
Sizing	According to ISO6336/DIN3990. 10,000 hrs average lifetime with service factor SF1
Housing, Covers	Pressure die cast aluminium up to size 4 and cast iron from size 5
Coupling G input	Pressure die cast aluminium for sizes G3, G5, G6 and alloyed steel from size G8
Toothed parts	Steel case hardened Tooth profile ground or shaved Run-in bevel gears
Shafts & Keys	Steel Tolerances: Shafts h6, Bores E8 Keys according to DIN6885 B1
Bearings	Ball- or roller-types according to sizes and technical requirements
Oil seals	Type NBR - Nitril-Butadiene Rubber with additional anti-dust lip according to DIN 3760 Type FKM - Fluor elastomer Viton on demand
Lubricant	Synthetic long-life oil Grade ISO VG 320
Painting	Aluminium until size 4 and Epoxy powder paint Standard colour RAL 7012 from size 5
ATEX	On demand

Gearboxes RD

Symbols

Symbol	Description
D [mm]	PCD of transmission element $k_{(t)}$
F_r [N]	Application radial load
F_{r1} [N]	Catalogue radial load (input)
F_{r2} [N]	Catalogue radial load (output)
$F_{r2b(x)}$ [N]	Permissible radial load at position "X" on output shaft. Based on bearing lifetime.
$F_{r2s(x)}$ [N]	Permissible radial load same as $F_{r2b(x)}$. Based on shaft bending and torsional stress.
FS	Service factor
i_n	Nominal reduction ratio $FS = \frac{M_2}{M_{(app)}}$
i_r	Actual reduction ratio
J_1 [kgm ²]	Moment of inertia of the gearbox at gearbox input shaft
J_2 [kgm ²]	Moment of inertia of the application
J_m [kgm ²]	Moment of inertia of the motor
$k_{(a)}$	Mass acceleration factor
$k_{(t)}$	Transmission element factor
Lub H/V [l]	Lubricant (litres) H - Horizontal mounting V - Vertical mounting
M_2 [Nm]	Gearbox maximum output torque
$M_{(app)}$ [Nm]	Application torque $M_2 = \frac{9550 * P_1 * \eta}{n_2}$
n_1 [min ⁻¹]	Input speed
n_2 [min ⁻¹]	Output speed
P_1 [kW]	Input power $P_1 = \frac{M_2 * n_2}{9550 * \eta}$
$P_{(kg)}$ [kg]	Weight: for mounting B3H and average reduction ratio
η	Efficiency $\eta = 0.96$ - 2 stages $\eta = 0.94$ - 3 stages

RD Gearboxes

Modular System

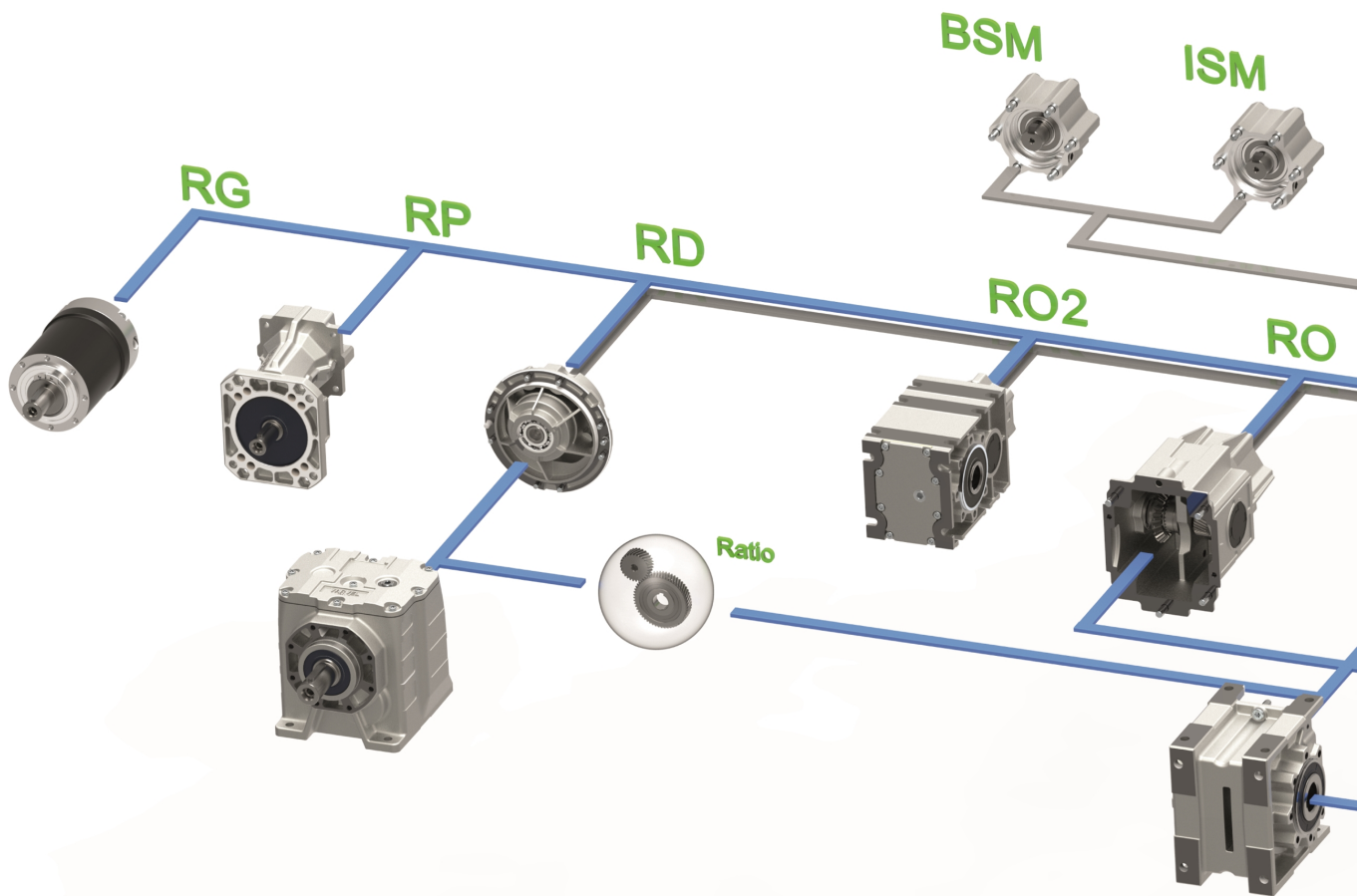

Gearboxes RD

Modular System

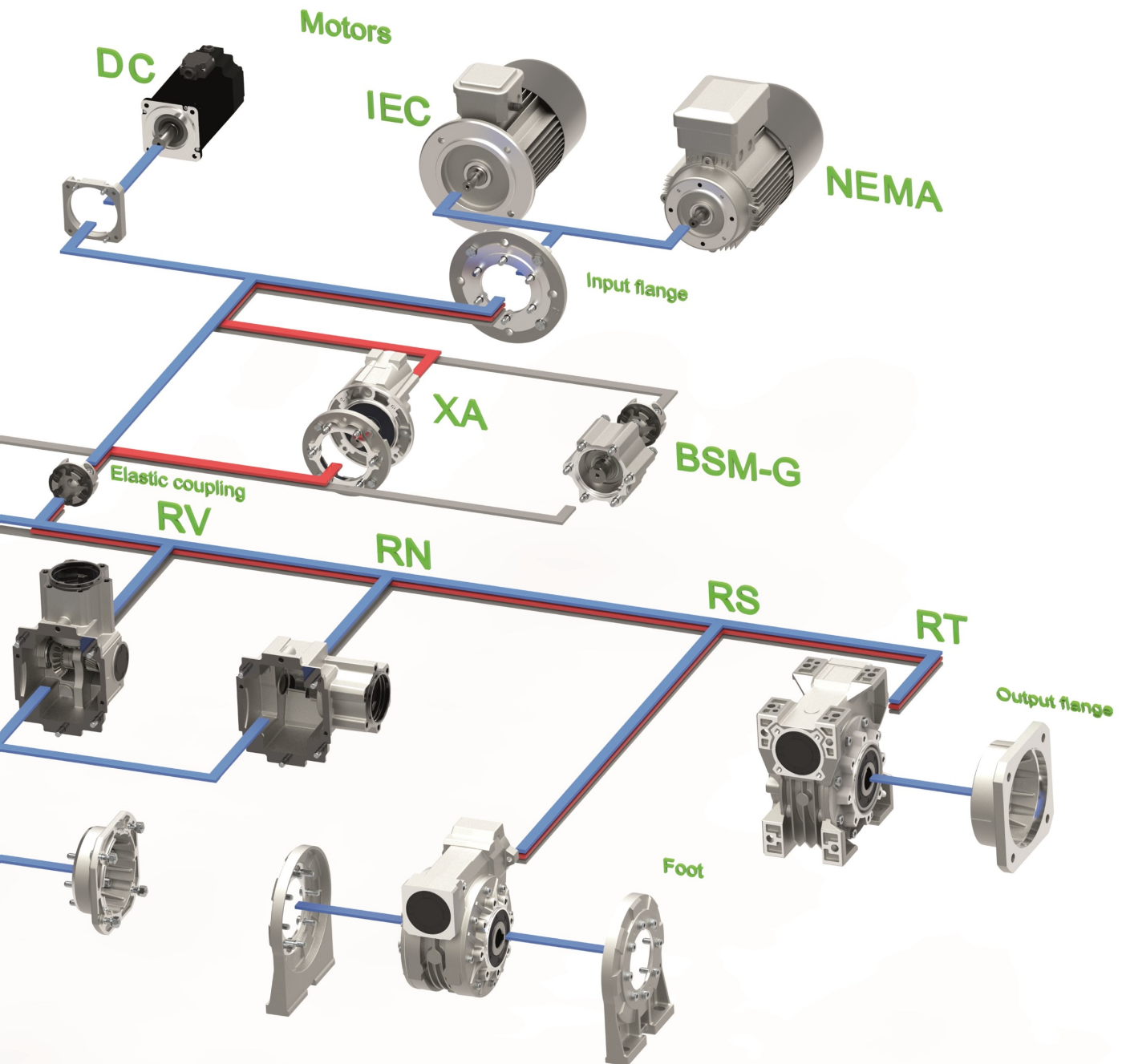

RD Gearboxes

Coupling G Description

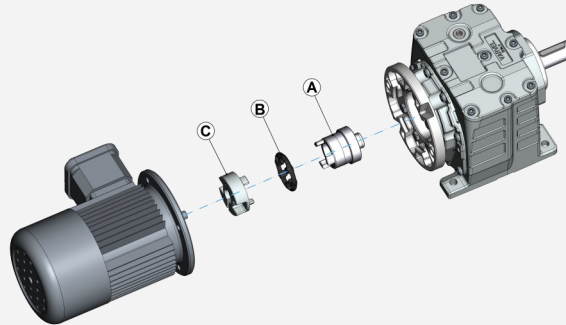

A)

Reducer-side coupling hub

- Material: steel
- One piece machined on input shaft
- Two bearing setting
- Unchanged casing dimensions

B)

Spider

- External tooth connection
- Material: Thermoplastic Elastomer: IXEF® - Polyarylamide
- Hardness 90 Shore D
- Temperature -30/+135°C (-22/+275°F)

C)

Motor-side coupling hub

- Material: Pressure die cast aluminium (G3, G5, G6) Steel (GS3, GS5, GS6, GS8)
- Dynamic balancing
- Fitting: Clamp (G3, G5, G6) Key (GS3, GS5, GS6, GS8)
- Bores, available according to: IEC 72 / DIN42948 NEMA C and TC

Advantages:

- One gearbox only for each reduction ratio
- Greater flexibility
- Increased stock rotation
- Elimination of fretting corrosion between key and keyway
- Gearbox / motor connection with zero backlash
- Allowed angular misalignment 1° max.
- High torsional rigidity
- High vibration damping

Input flanges:

- Material: Aluminium up to IEC112 & NEMA TC180 Cast iron from IEC 132 & NEMA TC200

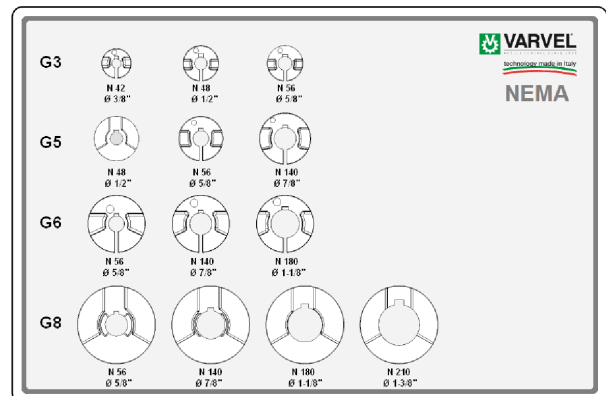
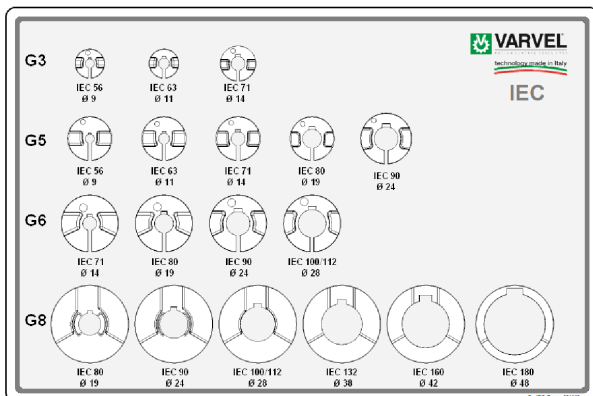

Gearboxes RD

Coupling G Selection

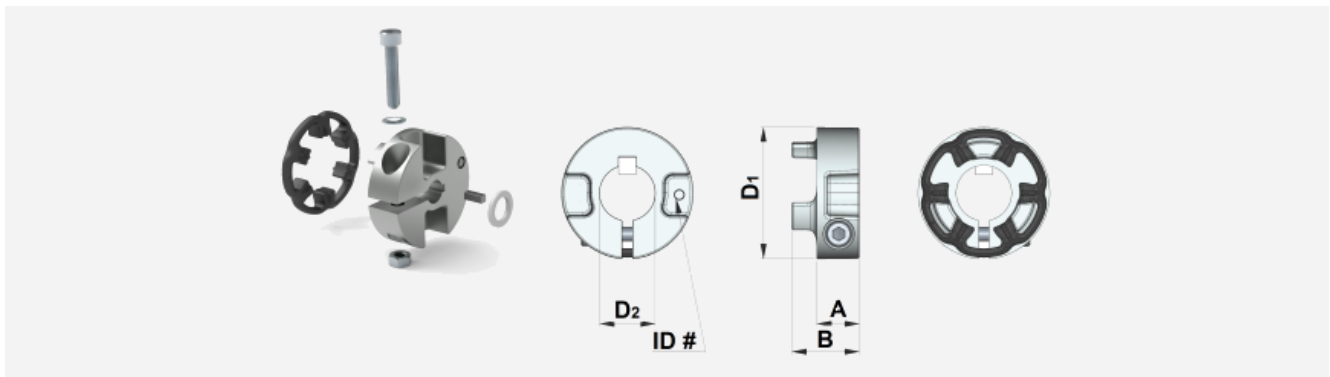

Type	IEC NEMA	Kit Code.	RD	Mt [Nm]	Mt ₁ [Nm]	Mt ₂ [Nm]	A [mm]	B [mm]	D ₁ [mm/ inch]	D ₂ [mm/ inch]	ID#
G3	IEC	KG3.009/X KG3.011/X KG3.014/X	03	4.5 - 6 4.5 - 6 7 - 8.5	15 15 28	8 - 10 8 - 10 18 - 22	11	19	30 30 36	9 11 14	309 311 314
	NEMA	KG3.N42/X KG3.N48/X	03	4.5 - 6 4.5 - 6	16 18	8 - 10 10 - 12			30 36	3/8" 1/2"	3N42 3N48
G5	IEC	KG5.009/X KG5.011/X KG5.014/X KG5.019/X KG5.024/X	02-12-13-23 02-12-13-23 02-12-13-23 02-12-23 12-23	8.9 - 10	14 15 30 40 70	8 - 10 8 - 10 12 - 17 20 - 25 30 - 40	14.5	23	45 45 45 45 52	9 11 14 19 24	509 511 514 519 524
	NEMA	KG5.N48/X KG5.N56/X KG5.N140/X	02 02-12-13-23 12-23		30 45 60	20 - 24 30 - 35 40 - 45			40 45 52	1/2" 5/8" 7/8"	5N48 5N56 5N140
G6	IEC	KG6.014/X KG6.019/X KG6.024/X KG6.028/X	22-32-33-42-43 22-32-33-42-43 22-32-33-42-43 22-32-42	15.3 - 18	60 90 130 180	30 - 40 50 - 65 85 - 100 100 - 120	19.5	31.5	58	14 19 24 28	614 619 624 628
	NEMA	KG6.N56/X KG6.N140/X KG6.N180/X	22-32-33-42-43 22-32-33-42-43 22-32-42-43		50 85 200	--- --- ---				5/8" 7/8" 1-1/8"	6N56 6N140 6N180
GS8*	IEC	KGS8.19/X KGS8.24/X KGS8.28/X KGS8.38/X KGS8.42/X KGS8.48/X	52-53-62-63 52-53-62-63 52-53-62-63 52-62-63 52-62 52-62	15	150 250 350 500 500 500	--- --- --- --- --- ---	35	51	79	19 24 28 38 42 48	819 824 828 838 842 848
	NEMA	KGS8.N056/X KGS8.N140/X KGS8.N180/X KGS8.N210/X	52-53-62-63 52-53-62-63 52-53-62-63 52-53-62-63		140 200 300 500	--- --- --- ---				5/8" 7/8" 1-1/8" 1-3/8"	8N56 8N140 8N180 8N210

Mt - Screw locking torque

Mt₁ - Transmissible torque with key

Mt₂ - Transmissible torque without key

* - Coupling GS8: steel, key fit and grub screw

../X - Code of coupling with IXEF black-spider

Note - No ID# marked on Coupling GS8

RD Gearboxes

IEC Flanges & Coupling

Gearbox Size	Flange Type	IEC Motor size	Flange Kit Part No.		Coupling		
			B5	B14	Type	Kit Part No.	
RD 02	FM 40	56	K531.206.120	K531.206.080	G5 ø9	KG5.009/X	
		63	K531.206.140	K531.206.090	G5 ø11	KG5.011/X	
		71	K531.206.160	K531.206.105	G5 ø14	KG5.014/X	
		80	---	K531.206.120	G5 ø19	KG5.019/X	
RD 03		56	K531.206.120	K531.206.080	G3 ø9	KG3.009/X	
		63	K531.206.140	K531.206.090	G3 ø11	KG3.011/X	
		71	K531.206.160	K531.206.105	G3 ø14	KG3.014/X	
RD 12		FM 50	56	K532.206.120	---	G5 ø9	KG5.009/X
	63		K532.206.140	K532.206.090	G5 ø11	KG5.011/X	
	71		K532.206.160	K532.206.105	G5 ø14	KG5.014/X	
	80		K532.206.200	K532.206.120	G5 ø19	KG5.019/X	
	90		K532.206.200	K532.206.140	G5 ø24	KG5.024/X	
RD 13	56		K532.206.120	---	G5 ø9	KG5.009/X	
	63		K532.206.140	K532.206.090	G5 ø11	KG5.011/X	
	71		K532.206.160	K532.206.105	G5 ø14	KG5.014/X	
RD 22	FM 70		63	K533.206.140	---	G5 ø11	KG5.011/X
			71	K533.206.160	K533.206.105	G6 ø14	KG6.014/X
		80	K533.206.200	K533.206.120	G6 ø19	KG6.019/X	
		90	K533.206.200	K533.206.140	G6 ø24	KG6.024/X	
		100/112	K533.206.250	K533.206.160	G6 ø28	KG6.028/X	
RD 23		63	K533.206.140	---	G5 ø11	KG5.011/X	
		71	K533.206.160	K533.206.105	G5 ø14	KG5.014/X	
		80	K533.206.200	K533.206.120	G5 ø19	KG5.019/X	
		90	K533.206.200	K533.206.140	G5 ø24	KG5.024/X	
RD 32		FM 70	63	K533.206.140	---	G5 ø11	KG5.011/X
	71		K533.206.160	K533.206.105	G6 ø14	KG6.014/X	
	80		K533.206.200	K533.206.120	G6 ø19	KG6.019/X	
	90		K533.206.200	K533.206.140	G6 ø24	KG6.024/X	
	100/112		K563.206.250	K533.206.160	G6 ø28	KG6.028/X	
RD 33	63		K533.206.140	---	G5 ø11	KG5.011/X	
	71		K533.206.160	K533.206.105	G6 ø14	KG6.014/X	
	80		K533.206.200	K533.206.120	G6 ø19	KG6.019/X	
RD 42	FM 85		71	K534.206.160	---	G6 ø14	KG6.014/X
			80	K534.206.200	K534.206.120	G6 ø19	KG6.019/X
		90	K534.206.200	K534.206.140	G6 ø24	KG6.024/X	
		100/112	K534.206.250	K534.206.160	G6 ø28	KG6.028/X	
		132	K534.206.300	K534.206.200	G6 ø38	KG6.038X	
RD 43		71	K534.206.160	---	G6 ø14	KG6.014/X	
		80	K534.206.200	K534.206.120	G6 ø19	KG6.019/X	
		90	K534.206.200	K534.206.140	G6 ø24	KG6.024/X	
RD 52		FM 130 & FM 150	80	K536.206.200	---	* GS8 ø19	KGS8.019/X
			90	K536.206.200	---	* GS8 ø24	KGS8.024/X
	100/112		K536.206.250	---	* GS8 ø28	KGS8.028/X	
	132		K537.206.300	K536.206.200	* GS8 ø38	KGS8.038/X	
	160		K565.206.350	K536.206.250	* GS8 ø42	KGS8.042/X	
	180		K565.206.350	---	* GS8 ø48	KGS8.048/X	
RD 53	80		K536.206.200	---	* GS8 ø19	KGS8.019/X	
	90		K536.206.200	---	* GS8 ø24	KGS8.024/X	
	100/112		K536.206.250	---	* GS8 ø28	KGS8.028/X	
RD 62	FM 130 & FM 150		80	K536.206.200	---	* GS8 ø19	KGS8.019/X
			90	K536.206.200	---	* GS8 ø24	KGS8.024/X
			100/112	K536.206.250	---	* GS8 ø28	KGS8.028/X
		132	K537.206.300	K536.206.200	* GS8 ø38	KGS8.038/X	
		160	K565.206.350	K536.206.250	* GS8 ø42	KGS8.042/X	
		180	K565.206.350	---	* GS8 ø48	KGS8.048/X	
RD 63		80	K536.206.200	---	* GS8 ø19	KGS8.019/X	
		90	K536.206.200	---	* GS8 ø24	KGS8.024/X	
		100/112	K536.206.250	---	* GS8 ø28	KGS8.028/X	
		132	K537.206.300	K536.206.200	* GS8 ø38	KGS8.038/X	

* - Coupling GS8: key fitting and axial locking grub screw
 ../X - Code of coupling with IXEF black-spider

Gearboxes RD

NEMA Flanges & Couplings

Gearbox Size	Flange Type	NEMA Motor size	Flange Kit Code	Coupling Kit	
				Typ	Code
RD 02	FM 40	48 C	K531.227.N48	G5 ø 1/2"	KG5.N48/X
		56 C	K531.227.N56	G5 ø 5/8"	KG5.N56/X
RD 03	FM 40	42 C	K531.227.N48	G3 ø 3/8"	KG3.N42/X
		48 C	K531.227.N48	G3 ø 1/2"	KG3.N48/X
RD 12	FM 50	56 C	K532.227.N56	G5 ø 5/8"	KG5.N56/X
		140 TC	K532.227.N56	G5 ø 7/8"	KG5.N140/X
RD 13	FM 50	56 C	K532.227.N56	G5 ø 5/8"	KG5.N56/X
RD 22	FM 70	56 C	K533.227.N56	G6 ø 5/8"	KG6.N56/X
		140 C	K533.227.N56	G6 ø 7/8"	KG6.N140/X
		180 C	K533.227.N180	G6 ø 1-1/8"	KG6.N180/X
RD 23	FM 70	56 C	K533.227.N56	G5 ø 5/8"	KG5.N56/X
		140 C	K533.227.N56	G5 ø 7/8"	KG5.N140/X
RD 32	FM 70	56 C	K533.227.N56	G6 ø 5/8"	KG6.N56/X
		140 TC	K533.227.N56	G6 ø 7/8"	KG6.N140/X
		180 TC	K533.227.N180	G6 ø 1-1/8"	KG6.N180/X
RD 33	FM 70	56 C	K533.227.N56	G6 ø 5/8"	KG6.N56/X
		140 TC	K533.227.N56	G6 ø 7/8"	KG6.N140/X
RD 42	FM 85	56 C	K534.227.N56	G6 ø 5/8"	KG6.N56/X
		140 TC	K534.227.N56	G6 ø 7/8"	KG6.N140/X
		180 TC	K534.227.N180	G6 ø 1-1/8"	KG6.N180/X
RD 43	FM 85	56 C	K534.227.N56	G6 ø 5/8"	KG6.N56/X
		140 TC	K534.227.N56	G6 ø 7/8"	KG6.N140/X
		180 TC	K534.227.N180	G6 ø 1-1/8"	KG6.N180/X
RD 52	FM 150	56 C	K537.227.N56	* GS8 ø 5/8"	KGS8.N56/X
		140 TC	K537.227.N56	* GS8 ø 7/8"	KGS8.N140/X
		180 TC	K537.227.N180	* GS8 ø 1-1/8"	KGS8.N180/X
		210 TC	K537.227.N180	* GS8 ø 1-3/8"	KGS8.N210/X
RD 53	FM 150	56 C	K537.227.N56	* GS8 ø 5/8"	KGS8.N56/X
		140 TC	K537.227.N56	* GS8 ø 7/8"	KGS8.N140/X
		180 TC	K537.227.N180	* GS8 ø 1-1/8"	KGS8.N180/X
		210 TC	K537.227.N180	* GS8 ø 1-3/8"	KGS8.N210/X
RD 62	FM 150	56 C	K537.227.N56	* GS8 ø 5/8"	KGS8.N56/X
		140 TC	K537.227.N56	* GS8 ø 7/8"	KGS8.N140/X
		180 TC	K537.227.N180	* GS8 ø 1-1/8"	KGS8.N180/X
		210 TC	K537.227.N210	* GS8 ø 1-3/8"	KGS8.N210/X
RD 63	FM 150	56 C	K537.227.N56	* GS8 ø 5/8"	KGS8.N56/X
		140 TC	K537.227.N56	* GS8 ø 7/8"	KGS8.N140/X
		180 TC	K537.227.N180	* GS8 ø 1-1/8"	KGS8.N180/X
		210 TC	K537.227.N210	* GS8 ø 1-3/8"	KGS8.N210/X

* - Coupling GS8: key fitting and axial locking grub screw
 ../X - Code of coupling with IXEF black-spider

RD Gearboxes

Gearbox & Motor Designation

GEARBOX DESIGNATION

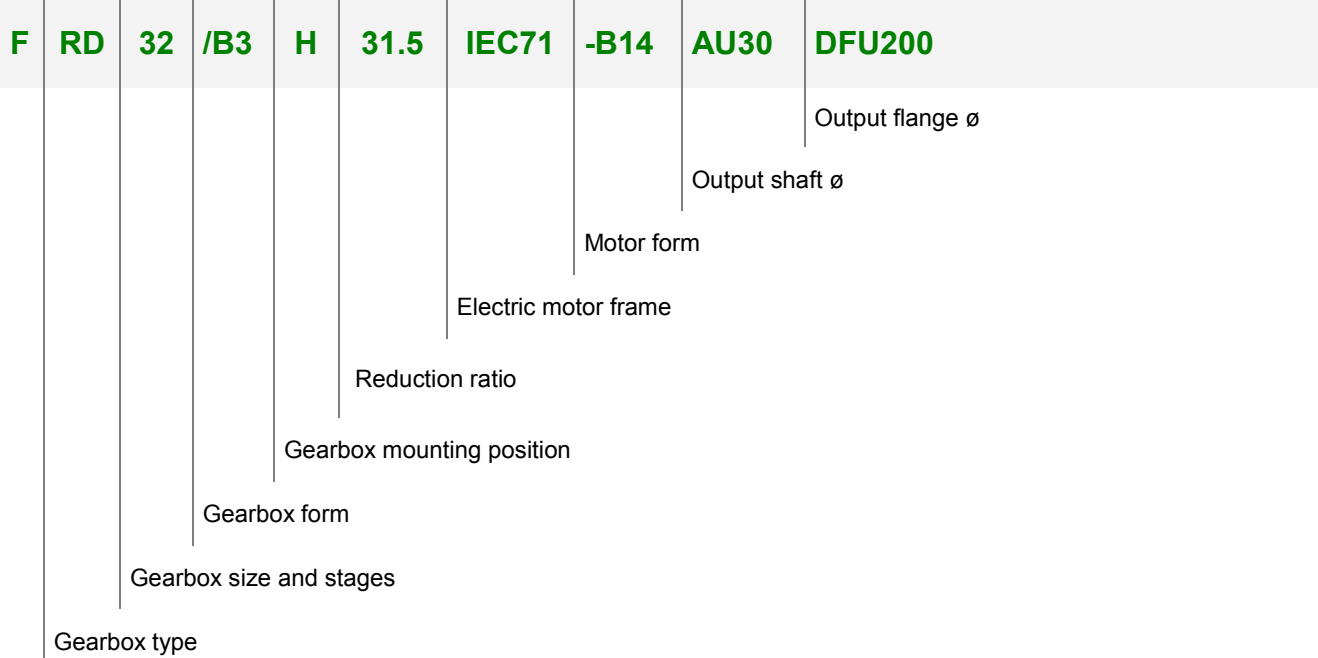

- M = Geared motor
- F = Gearbox with input flange
- S = Gearbox without input flange
- ... = (nothing) Gearbox with input free shaft

MOTOR DESIGNATION

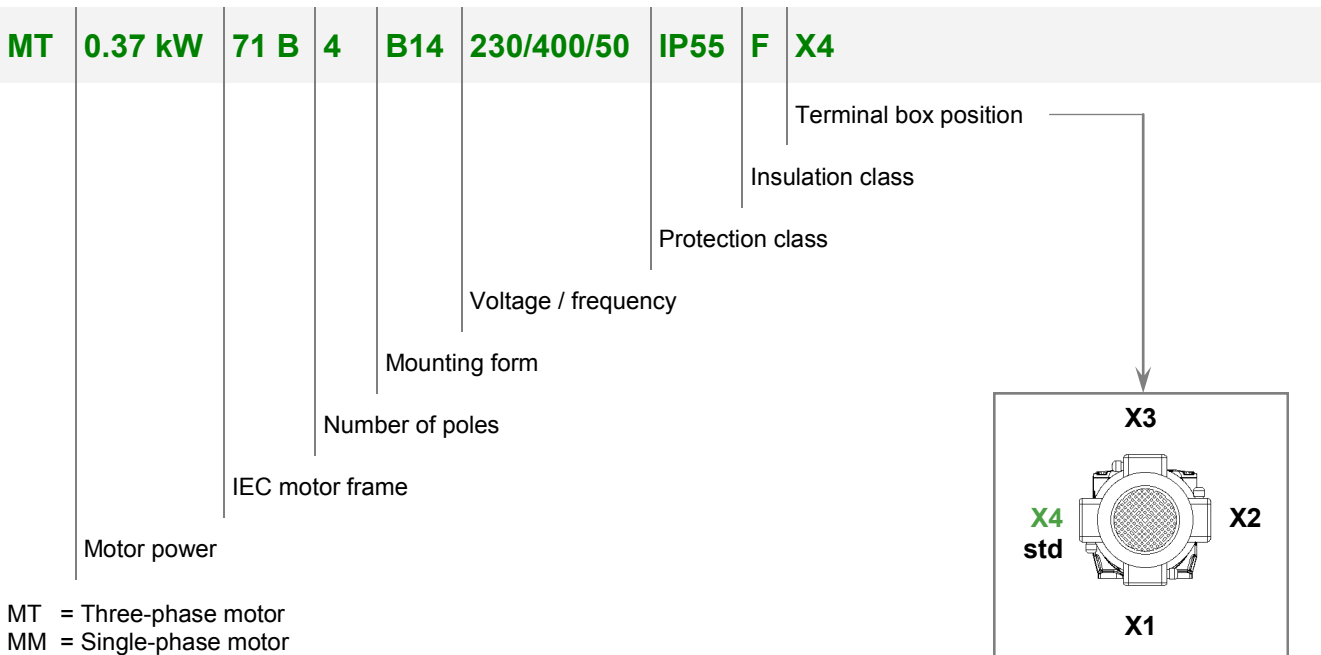

- MT = Three-phase motor
- MM = Single-phase motor
- MA = Brake motor



Modularity and flexibility

have been leading the design of VARVEL products since the years 2000.

This way, the gearbox-kit concept was carried out allowing anyone to assemble the unit in few minutes with standard tooling.

That feature provides the highest flexibility to VARVEL's distributors and resellers who - thanks to a limited kit selection - are able to immediately configure the required product.

VARsize® selection program, available from our web-site

www.varvel.com

allows a friendly sizing of VARVEL product range.

2D/3D Drawings

A guided selection lets 2D/3D models downloaded for the most popular CAD systems.

Guided selection

This option returns a list of applicable product configurations upon a given sequence of application parameters (power, output torque, rpm, service factor etc.); a PDF data sheet featuring performance data and dimensional drawings is generated for each configuration, as well as the 3D model and 2D drawings.

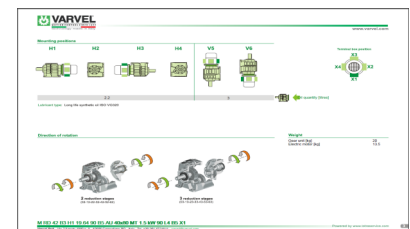
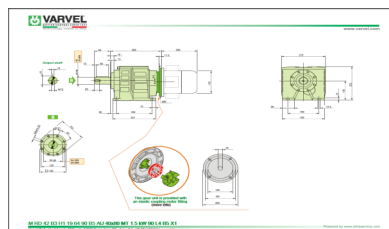
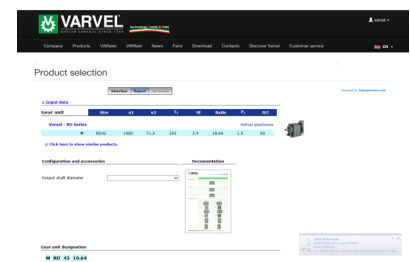
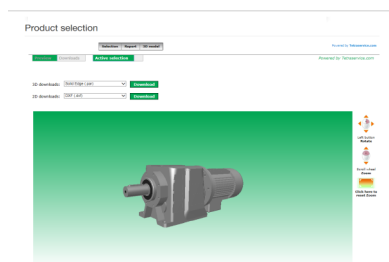
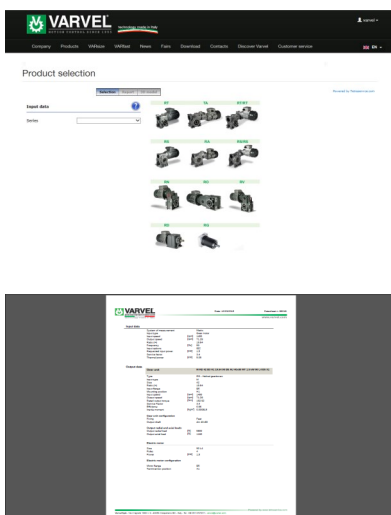

RD Gearboxes

Mounting positions

RD

- two and three stages

B3
Foot mounting

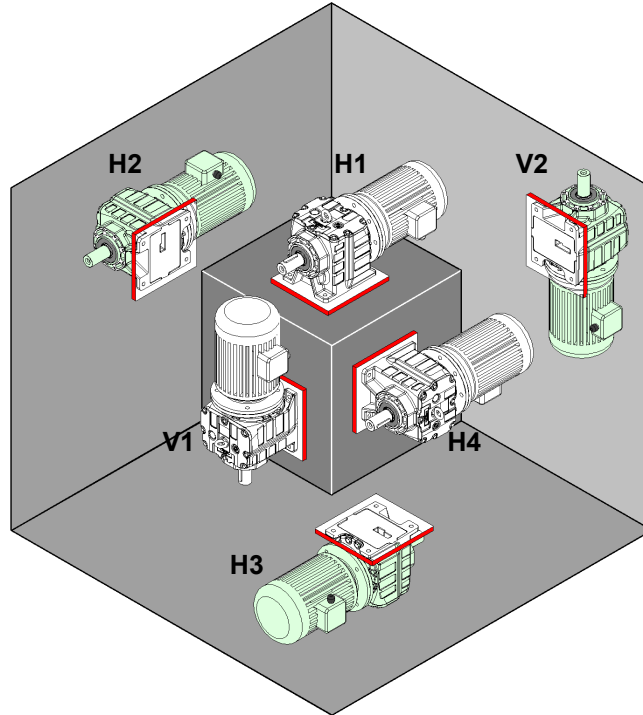

B5
Flange mounting

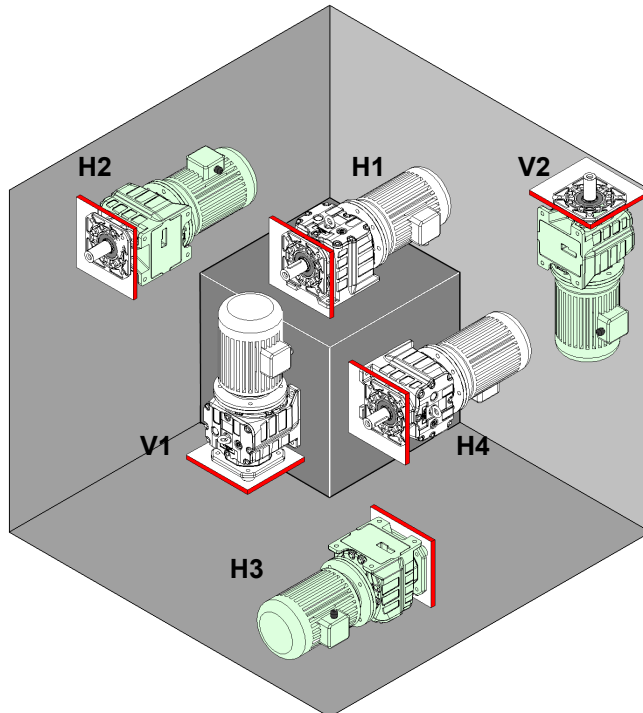

Gearboxes RD

Service factors

SERVICE FACTOR of the gearbox

Service factor FS1.0 is meant as typical of 8 hours/day operation, with uniform load and mass acceleration factor $k_{(a)} \leq 0.2$, starts/ stops lower than 60 per hour and ambient temperature between 15 and 35 Celsius.

The ratio between the drive's maximum output torque M_2 and application torque $M_{(app)}$ defines the drive's Duty Factor that must be equal or bigger than the Service Factor SF.

Thermal power (see page19) can be not considered when max. continuous operation is about 3 hours with rest periods long enough (about 2 to 4 hours) to restore the ambient temperature into the gearbox.

For max. ambient temperature exceeding 40 °C or below 0 °C, please ask our Customer Service.

Service factor SF

Load type				Start-Stops / hour		SF = SF ₁ x SF ₂
Hours	Uniform SF ₁	Variable SF ₁	Shock SF ₁	Number	SF ₂	
8	0.8	1.1	1.4	60	1.0	
16	1.0	1.3	1.5	600	1.2	
24	1.2	1.4	1.6	1200	1.3	

Mass acceleration factor

$$k_{(a)} = \frac{\frac{J_2}{i r^2} + J_1}{J_m}$$

Load class

- A - Uniform load
 $k_{(a)} \leq 0,2$
- B - Moderate shock load
 $0,2 > k_{(a)} \leq 3$
- C - Severe shock load
 $3 < k_{(a)} \leq 10$

A/h - Number of starts/stops per hour

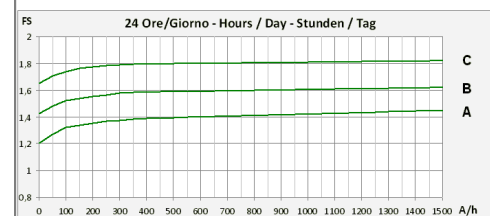
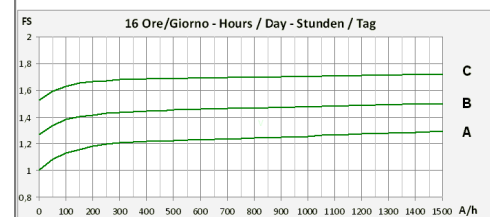
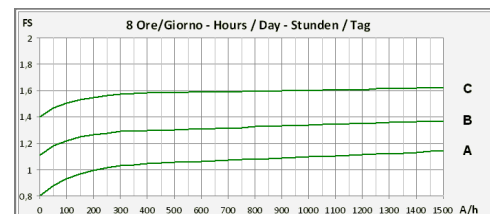

RD Gearboxes

Service factors

DUTY TYPE of the motor

Duty types are defined by CEI EN 60034-1 / IEC34-1 Standard.

S1 - Continuous duty

Steady load operation for an indefinite period (N), but long enough to achieve thermal balancing.

$$FS = 1.0$$

N = Operation time

c = Load

t = Temperature

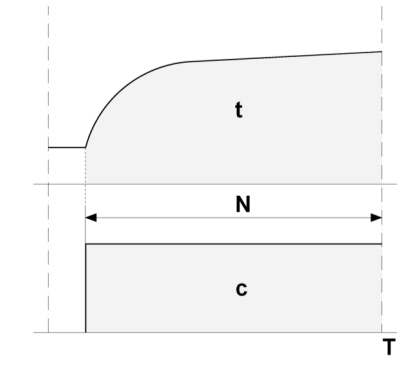

S3 - Periodic intermittent duty

Operation according to cycle (C) including steady load time (N) and rest time (R).

Starts/stops do not affect temperature.

The reference cycle (C) to count as a total of 10 minutes.

Intermittence ratio is calculated according the following formula.

$$\frac{N}{(N+R)} * 100 = \begin{matrix} 60\% & \text{FS 1.1} \\ 40\% & \text{FS 1.2} \\ 25\% & \text{FS 1.3} \\ 15\% & \text{FS 1.4} \end{matrix}$$

N = Operation time

R = Rest time

C = Duty cycle

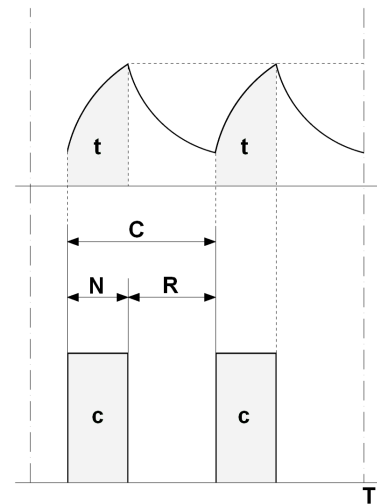

Gearboxes RD

External Loads

OUTPUT RADIAL LOADS (OHL)

The radial (overhung) load shown in the tables should be checked according to output speed, mounting position (A) and type of the transmission element (B) fitted on the gearbox output shaft by the appropriate k_L and k_T rating factors.

A - Application point of radial load

OHL is considered as applied at the output shaft mid-point.
Other positions origin loads to be adjusted with the appropriate factor k_L .
Examples of the distance from the shaft shoulder follow.

k_L	L
1.1	1/4 * L
1.0	1/2 * L
0.9	3/4 * L
0.8	L

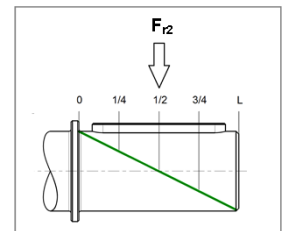

B - Transmission element

k_T	Element type
1.15	Gear tooth No. < 17
1.40	Chain sprocket tooth No. < 13
1.25	tooth No. < 20
1.00	tooth No. > 20
2.50	Pulley for V-belt
1.25	toothed-belt

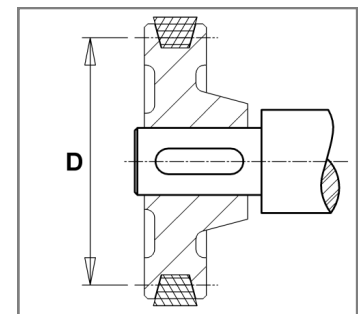

F_{r2} - Radial (overhung) load

$$F_{r2} = \frac{2000 * M_2}{D} \times k_L \times k_T$$

OUTPUT AXIAL LOADS

Axial load value

$$F_{a2} = F_{r2} \times 0.2$$

is included within the catalogue radial load figure
and is valid on both tensile and compressive stress.

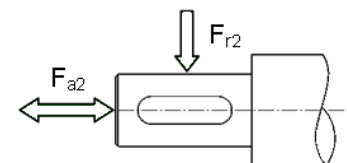

RD Gearboxes

Versions

MRD

Geared motors with two and three gear sets
Powers: 0.06 kW to 22 kW, 4 poles
Output speed: 600 rpm to 2.2 rpm

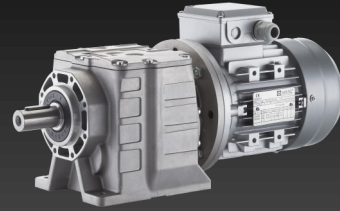

FRD

Gearboxes with two and three gear sets and with input motor flange, input quill and flexible coupling
Motor flanges: IEC 56 to IEC 180 and NEMA 56C to NEMA 210TC
Output torque: 27 Nm [240 in-lb] to 2300 Nm [20350 in-lb]
Reduction ratios: 2.25:1 to 630:1

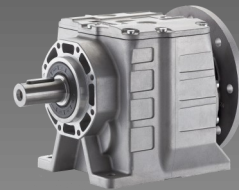

SRD

Gearboxes with two and three gear sets without input motor flange, but with input hollow shaft and flexible coupling
Output torque: 27 Nm [240 in-lb] to 2300 Nm [20350 in-lb]
Reduction ratios: 2.25:1 to 630:1

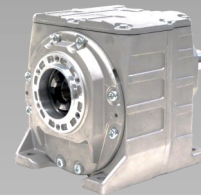

RD

Gearboxes with two and three gear sets and input solid shaft
Output torque: 27 Nm [240 in-lb] to 2300 Nm [20350 in-lb]
Reduction ratios: 2.25:1 to 630:1

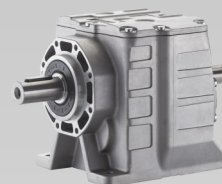

Gearboxes RD

Thermal power

Thermal power

Rated power (P_1) is the power that can be applied at the gearbox input, on continuous operation, max. temperature of 40 °C, max. altitude 1000 m and air speed of 1.25 m/s, without exceeding the oil temperature of about 85 °C.

Thermal power (P_{t1}) can limit the rated P_1 (shaded area) depending on the cooling system, input speed, ambient temperature and service factor.

	i_n	FRD 02-03		FRD 12 - 13		FRD 22 - 23		FRD 32 - 33		FRD 42 - 43		FRD 52 - 53		FRD 62 - 63		
		P_1 [kW]	P_{t1} [kW]	P_1 [kW]	P_{t1} [kW]	P_1 [kW]	P_{t1} [kW]	P_1 [kW]	P_{t1} [kW]	P_1 [kW]	P_{t1} [kW]	P_1 [kW]	P_{t1} [kW]	P_1 [kW]	P_{t1} [kW]	
Two stages	2,25	1,80	0,24	2,70	1,83	5,30	2,33	11,20	6,76	18,80	7,85	39,10	7,22	78,20	13,75	
	2,50	1,82	0,26	2,50	1,86	4,99	2,46	10,49	7,17	17,70	7,52	34,00	7,49	70,00	14,07	
	2,80	1,60	0,26	2,40	1,73	4,60	2,28	9,80	6,34	16,30	7,29	33,50	7,25	67,00	14,40	
	3,15	1,57	0,27	2,21	1,75	4,37	2,40	9,18	6,68	15,30	6,99	30,00	7,45	60,00	14,55	
	3,55	1,30	0,26	2,00	1,56	4,00	2,20	8,40	5,76	13,70	6,51	29,30	6,96	58,70	13,92	
	4,0	1,32	0,27	1,84	1,58	3,75	2,30	7,87	6,04	14,20	6,28	29,00	7,11	58,00	13,95	
	4,5	1,10	0,24	1,60	1,40	3,30	2,01	7,00	5,07	11,90	5,85	25,10	6,50	50,30	13,20	
	5,0	1,13	0,25	1,55	1,41	3,12	2,10	6,55	5,24	12,30	5,65	26,80	6,64	55,40	13,10	
	5,6	1,40	0,22	1,40	1,22	2,80	1,91	---	---	10,00	5,03	20,30	5,71	40,60	11,74	
	6,3	1,22	0,26	2,06	1,39	4,13	1,81	9,31	5,38	15,20	5,04	27,40	5,96	46,80	11,36	
	7,1	1,10	0,22	1,20	1,07	2,20	1,55	4,60	3,79	7,10	4,16	13,60	4,85	27,30	9,79	
	8,0	0,97	0,25	1,71	1,33	3,39	1,82	7,63	5,00	12,30	4,78	21,80	5,67	36,60	11,15	
	9,0	0,89	0,22	0,76	0,82	1,40	1,45	---	---	4,90	3,76	8,70	4,54	20,80	9,40	
	10,0	0,78	0,25	1,33	1,23	2,74	1,76	6,17	4,62	9,80	4,43	18,10	5,37	31,70	10,39	
	12,5	0,62	0,23	1,06	1,09	2,17	1,64	4,87	4,12	8,00	4,14	14,80	5,10	25,70	9,72	
	16,0	0,49	0,21	0,88	0,96	1,78	1,54	3,72	3,55	6,60	3,74	11,80	4,58	20,30	8,86	
	20,0	0,38	0,18	0,71	0,86	1,42	1,32	3,19	3,22	5,70	3,22	9,10	3,98	15,50	7,70	
	25,0	0,31	0,15	0,56	0,71	1,11	1,22	2,48	2,87	4,20	2,95	7,20	3,70	13,00	7,43	
	31,5	0,27	0,13	0,46	0,63	0,95	1,08	1,68	2,38	3,50	2,62	6,00	3,28	10,00	6,10	
	35,5	0,16	0,15	---	---	---	---	---	---	---	---	---	---	---	---	---
40	0,13	0,12	0,27	0,60	0,53	1,00	1,10	2,36	1,50	2,10	3,20	3,01	6,00	5,87		
50	0,11	0,11	0,22	0,54	0,41	0,85	0,85	2,01	1,20	1,87	2,40	2,60	4,90	5,21		
63	---	---	0,17	0,45	0,34	0,75	0,69	1,76	1,10	1,39	1,90	2,26	4,30	4,77		
Three stages	40	0,22	0,32	0,38	0,71	0,75	1,21	1,68	1,88	2,50	2,39	5,00	1,86	8,60	4,92	
	50	0,18	0,31	0,29	0,67	0,59	1,16	1,33	1,76	2,10	2,28	4,10	1,78	7,00	4,58	
	63	0,14	0,30	0,23	0,64	0,48	1,11	1,01	1,61	1,50	2,13	3,40	1,66	5,50	4,16	
	80	0,11	0,29	0,19	0,60	0,39	1,00	0,87	1,51	1,70	1,94	2,60	1,49	4,40	3,67	
	100	0,09	0,27	0,16	0,55	0,30	0,94	0,67	1,38	1,10	1,84	2,10	1,39	3,70	3,39	
	125	0,07	0,26	0,12	0,48	0,25	0,86	0,51	1,23	0,90	1,69	1,60	1,17	3,40	3,05	
	160	0,05	0,23	0,10	0,41	0,19	0,68	0,40	1,06	0,70	3,72	1,30	1,24	2,80	2,66	
	180	0,05	0,22	---	---	---	---	---	---	---	---	---	---	---	---	---
	200	0,03	0,22	0,08	0,39	0,15	0,63	0,34	1,01	0,60	3,25	1,10	1,16	1,80	2,92	
	250	0,02	0,20	0,06	0,35	0,12	0,61	0,26	1,37	0,40	2,99	0,80	1,00	1,40	2,55	
	280	0,02	0,19	---	---	---	---	---	---	---	---	---	---	---	---	---
	315	0,02	0,18	0,05	0,33	0,10	0,58	0,22	0,91	0,35	2,64	0,45	0,88	1,10	2,26	
	400	---	---	0,03	0,31	0,06	0,55	0,11	1,21	0,22	2,20	0,35	0,80	1,60	2,17	
	500	---	---	0,02	0,30	0,04	0,50	0,09	0,80	0,12	1,73	0,30	0,72	0,80	2,21	
	560	---	---	---	---	---	---	---	---	---	---	---	---	0,70	1,98	
630	---	---	0,02	0,27	0,04	0,48	0,07	1,21	0,11	1,12	0,25	0,66	---	---		

RD Gearboxes

RD0 - 50 Nm

Speed Reducer Selection

1400 rpm

	i_n	i_r	n_2 [rpm]	M_2 [Nm]	P_1 [kW]	F_{r1} [N]	F_{r2} [N]	$J_1 (x 10^{-4})$ [kgm ²]	56	63	71	80
FRD02 2 c	2.25	2.314	605	27	1.8	*	400	0.6467	⊙	⊙	⊙	(⊙)
	2.5	2.568	545	30	1.82	*	430	0.5251	⊙	⊙	⊙	(⊙)
	2.80	2.952	474	30	1.60	*	410	0.4835	⊙	⊙	⊙	(⊙)
	3.15	3.277	427	33	1.57	*	420	0.4443	⊙	⊙	⊙	(⊙)
	3.55	3.834	365	34	1.3	*	420	0.4253	⊙	⊙	⊙	(⊙)
	4.0	4.256	329	36	1.32	*	430	0.3884	⊙	⊙	⊙	(⊙)
	4.5	4.753	295	34	1.10	*	470	0.3674	⊙	⊙	⊙	(⊙)
	5.0	5.276	265	38	1.13	*	520	0.3587	⊙	⊙	⊙	(⊙)
	5.6	5.747	244	52	1.40	*	580	0.3841	⊙	⊙	⊙	(⊙)
	6.3	6.253	234	48	1.22	*	640	0.4296	⊙	⊙	⊙	(⊙)
	7.1	7.333	191	53	1.10	*	680	0.4015	⊙	⊙	⊙	(⊙)
	8.0	7.979	175	49	0.97	*	720	0.3856	⊙	⊙	⊙	(⊙)
	9.0	9.524	147	54	0.89	*	770	0.3618	⊙	⊙	⊙	(⊙)
	10.0	10.362	135	50	0.78	*	820	0.3536	⊙	⊙	⊙	(⊙)
	12.5	12.844	109	50	0.62	*	920	0.3361	⊙	⊙	⊙	(⊙)
	16.0	16.320	86	51	0.49	*	1020	0.3218	⊙	⊙	⊙	
	20.0	21.533	65	51	0.38	*	1170	0.3106	⊙	⊙	⊙	
	25.0	26.747	52	52	0.31	*	1200	0.3045	⊙	⊙	⊙	
	31.5	30.222	46	52	0.27	*	1200	0.3019	⊙	⊙		
	35.5	34.675	40	35	0.16	*	638	1430	0.3089	⊙	⊙	
40	43.070	33	35	0.13	*	646	1430	0.3033	⊙	⊙		
50	48.667	29	35	0.11	*	651	1420	0.3010	⊙	⊙		
FRD03 3c	40	36.892	37	52	0.22	*	76	1200	0.3065	⊙	⊙	⊙
	50	47.074	30	52	0.18	*	149	1200	0.6431	⊙	⊙	⊙
	63	61.135	23	52	0.14	*	208	1200	0.6342	⊙	⊙	⊙
	80	75.782	18	52	0.11	*	248	1200	0.6299	⊙	⊙	
	100	96.288	15	52	0.09	*	281	1200	0.6270	⊙		
	125	127.047	11	52	0.07	*	312	1200	0.6252	⊙		
	160	157.805	8.9	52	0.05	*	332	1200	0.6244	⊙		
	180	178.311	7.9	52	0.05	*	341	1200	0.6241	⊙		
	200	204.583	6.9	36	0.03	*	367	1420	0.6251	⊙		
	250	254.113	5.5	36	0.02	*	376	1420	0.6244	⊙		
	280	287.133	4.9	36	0.02	*	380	1420	0.6241	⊙		
	315	324.444	4.3	36	0.02	*	380	1420	0.6462	⊙		

2c, 3c - Number of reduction stages

* - Drive via flexible coupling

⊙ - B5 and B14

(⊙) - B14 only

Lubrication (Oil litres) and Weights (kg)

	H	V	kg
FRD02	0.2	0.3	3.0
FRD03	0.3	0.4	3.2

RD1 - 100 Nm

Gearboxes RD

1400 rpm

Speed Reducer Selection

	i_n	i_r	n_2 [rpm]	M_2 [Nm]	P_1 [kW]	F_{r1} [N]	F_{r2} [N]	J_1 ($\times 10^{-4}$) [kgm ²]	56	63	71	80	90
FRD 12 2c	2.25	2.348	596	40	2.70	*	1200	1.2989	(⊙)	⊙	⊙	⊙	⊙
	2.5	2.534	560	45	2.50	*	1300	1.1152	(⊙)	⊙	⊙	⊙	⊙
	2.80	2.855	490	43	2.40	*	1350	0.1056	(⊙)	⊙	⊙	⊙	⊙
	3.15	3.081	445	45	2.21	*	1400	0.9332	(⊙)	⊙	⊙	⊙	⊙
	3.55	3.716	377	46	2.00	*	1450	0.8131	(⊙)	⊙	⊙	⊙	⊙
	4.0	4.011	350	50	1.84	*	1500	0.7691	(⊙)	⊙	⊙	⊙	⊙
	4.5	4.700	298	49	1.60	*	1550	0.7912	(⊙)	⊙	⊙	⊙	⊙
	5.0	5.073	280	55	1.55	*	1600	0.6732	(⊙)	⊙	⊙	⊙	⊙
	5.6	5.726	251	51	1.40	*	1650	0.7514	(⊙)	⊙	⊙	⊙	⊙
	6.3	6.686	220	90	2.06	*	1700	0.8357	(⊙)	⊙	⊙	⊙	⊙
	7.1	7.161	196	54	1.20	*	1750	0.7857	(⊙)	⊙	⊙	⊙	⊙
	8.0	8.129	175	90	1.71	*	1800	0.7441	(⊙)	⊙	⊙	⊙	⊙
	9.0	9.315	150	45	0.76	*	1850	0.7013	(⊙)	⊙	⊙	⊙	⊙
	10.0	10.581	140	90	1.33	*	1900	0.6575	(⊙)	⊙	⊙	⊙	⊙
	12.5	13.384	110	90	1.06	*	1900	0.6035	(⊙)	⊙	⊙	⊙	⊙
	16.0	16.309	90	90	0.88	20	1900	0.5710	(⊙)	⊙	⊙	⊙	
	20.0	20.391	70	90	0.71	55	1900	0.5435	(⊙)	⊙	⊙	⊙	
	25.0	26.522	55	95	0.56	75	2000	0.5211	(⊙)	⊙	⊙	⊙	
31.5	32.653	45	95	0.46	100	2000	0.5088	(⊙)	⊙	⊙			
40	39.083	35	70	0.27	590	2000	0.5184	(⊙)	⊙	⊙			
50	48.118	30	70	0.22	630	2000	0.5070	(⊙)	⊙	⊙			
63	61.670	22	70	0.17	640	2000	0.4975	(⊙)	⊙				
FRD 13 3c	40	40.103	35	95	0.38	120	1500	0.5267	(⊙)	⊙	⊙		
	50	52.201	30	95	0.29	210	1600	1.5521	(⊙)	⊙	⊙		
	63	66.028	22	95	0.23	270	1700	1.5394	(⊙)	⊙			
	80	80.432	18	100	0.19	320	1800	1.5333	(⊙)	⊙			
	100	100.596	14	100	0.16	350	1900	1.5288	(⊙)	⊙			
	125	130.843	11	100	0.12	400	2000	1.5260	(⊙)	⊙			
	160	165.075	9.0	100	0.10	410	2000	1.9460	(⊙)				
	200	206.460	7.0	100	0.08	420	2000	1.9423	(⊙)				
	250	268.538	5.5	100	0.06	430	2000	1.9401	(⊙)				
	315	330.615	4.5	100	0.05	450	2000	1.9391	(⊙)				
	400	395.719	3.5	70	0.03	480	2200	1.9401	(⊙)				
	500	487.197	2.8	70	0.02	490	2200	1.9391	(⊙)				
	630	624.413	2.2	70	0.02	510	2200	1.9385	(⊙)				

- 2c, 3c - Number of reduction stages
 * - Drive via flexible coupling
 ⊙ - B5 and B14
 (⊙) - B5 only

Lubrication (Oil litres) and Weights (kg)

	H	V	kg
FRD12	0.5	0.7	4.8
FRD13	0.5	0.7	4.8

RD Gearboxes

RD2 - 200 Nm

Speed Reducer Selection

1400 rpm

	i_n	i_r	n_2 [rpm]	M_2 [Nm]	P_1 [kW]	F_{r1} [N]	F_{r2} [N]	J_1 ($\times 10^{-4}$) [kgm ²]	63	71	80	90	100	112
FRD 22 2c	2.25	2.313	599	79	5.30	*	1000	4.1128	(⊙)	⊙	⊙	⊙	⊙	⊙
	2.5	2.548	560	85	4.99	*	1100	3.4569	(⊙)	⊙	⊙	⊙	⊙	⊙
	2.80	2.846	487	85	4.60	*	1200	3.1032	(⊙)	⊙	⊙	⊙	⊙	⊙
	3.15	3.133	445	90	4.37	*	1350	2.8995	(⊙)	⊙	⊙	⊙	⊙	⊙
	3.55	3.558	390	91	4.00	*	1400	2.6305	(⊙)	⊙	⊙	⊙	⊙	⊙
	4.0	3.917	350	100	3.75	*	1500	2.4858	(⊙)	⊙	⊙	⊙	⊙	
	4.5	4.554	304	97	3.30	*	1600	2.2505	(⊙)	⊙	⊙	⊙	⊙	
	5.0	5.013	280	105	3.12	*	1700	2.1816	(⊙)	⊙	⊙	⊙	⊙	
	5.6	5.609	247	102	2.80	*	1760	2.5308	(⊙)	⊙	⊙	⊙	⊙	
	6.3	6.717	220	175	4.13	*	1850	2.7248	(⊙)	⊙	⊙	⊙	⊙	
	7.1	7.115	195	99	2.20	*	1910	2.6423	(⊙)	⊙	⊙	⊙	⊙	
	8.0	8.267	175	180	3.39	*	2000	2.4162	(⊙)	⊙	⊙	⊙	⊙	
	9.0	9.203	151	83	1.40	*	2040	2.2654	(⊙)	⊙	⊙	⊙	⊙	
	10.0	10.333	140	180	2.74	*	2100	2.1765	(⊙)	⊙	⊙	⊙	⊙	
	12.5	13.227	110	180	2.17	*	2200	1.9928	(⊙)	⊙	⊙	⊙	⊙	
	16.0	16.290	90	185	1.78	*	2300	1.8826	(⊙)	⊙	⊙	⊙		
	20.0	20.667	70	190	1.42	*	2400	1.7924	(⊙)	⊙	⊙	⊙		
	25.0	26.729	55	190	1.11	40	2500	1.7234	(⊙)	⊙	⊙	⊙		
	31.5	31.477	45	190	0.95	50	2600	1.6937	(⊙)	⊙	⊙	⊙		
	40	39.388	35	140	0.53	720	2900	1.6604	(⊙)	⊙	⊙			
50	50.758	30	140	0.41	740	3050	1.6757	(⊙)	⊙					
63	62.127	22	140	0.34	760	3200	1.6537	(⊙)	⊙					
FRD 23 3c	40	40.759	35	200	0.75	140	2300	1.7501	(⊙)	⊙	⊙	⊙		
	50	52.172	30	200	0.59	280	2400	2.5709	(⊙)	⊙	⊙	⊙		
	63	64.256	22	200	0.48	380	2500	2.5490	(⊙)	⊙	⊙	⊙		
	80	81.519	18	200	0.39	460	2600	2.5337	(⊙)	⊙				
	100	105.431	14	200	0.30	550	2700	2.5230	(⊙)	⊙				
	125	124.159	11	200	0.25	590	2800	2.5195	(⊙)	⊙				
	160	164.938	9.0	200	0.19	430	2900	3.0999	(⊙)					
	200	209.250	7.0	200	0.15	520	3000	3.0889	(⊙)					
	250	270.630	5.5	200	0.12	580	3200	3.0816	(⊙)					
	315	318.704	4.5	200	0.10	600	3500	3.0796	(⊙)					
	400	398.802	3.5	140	0.06	700	3500	3.0809	(⊙)					
	500	513.920	2.8	140	0.04	730	3500	3.0790	(⊙)					
	630	629.039	2.2	140	0.04	760	3500	3.0783	(⊙)					

- 2c, 3c - Number of reduction stages
- * - Drive via flexible coupling
- ⊙ - B5 and B14
- (⊙) - B5 only

Lubrication (Oil litres) and Weights (kg)

	H	V	kg
FRD22	0.8	1.0	7.9
FRD23	0.8	1.0	8.5

RD3 - 420 Nm

Gearboxes RD

1400 rpm

Speed Reducer Selection

	i_n	i_r	n_2 [rpm]	M_2 [Nm]	P_1 [kW]	F_{r1} [N]	F_{r2} [N]	J_1 ($\times 10^{-4}$) [kgm ²]	63	71	80	90	100	112
FRD 32 2c	2.25	2.420	579	171	11.20	800	2000	9.3605	(⊙)	⊙	⊙	⊙	⊙	⊙
	2.5	2.697	560	190	10.49	830	2100	7.5606	(⊙)	⊙	⊙	⊙	⊙	⊙
	2.80	2.983	469	184	9.80	840	2100	6.5382	(⊙)	⊙	⊙	⊙	⊙	⊙
	3.15	3.324	445	205	9.18	850	2200	5.9052	(⊙)	⊙	⊙	⊙	⊙	⊙
	3.55	3.733	375	198	8.40	860	2200	5.4374	(⊙)	⊙	⊙	⊙	⊙	⊙
	4.0	4.160	350	220	7.87	880	2300	4.6789	(⊙)	⊙	⊙	⊙	⊙	
	4.5	4.783	293	211	7.00	890	2400	4.2591	(⊙)	⊙	⊙	⊙	⊙	
	5.0	5.331	280	235	6.55	900	2500	3.7739	(⊙)	⊙	⊙	⊙	⊙	
	6.3	6.261	220	370	9.31	920	2700	5.2968	(⊙)	⊙	⊙	⊙	⊙	
	7.1	7.484	187	217	4.6	960	2900	4.6784	(⊙)	⊙	⊙	⊙	⊙	
	8.0	7.717	175	370	7.63	980	3100	4.4149	(⊙)	⊙	⊙	⊙	⊙	
	10.0	9.658	140	375	6.17	1030	3600	3.7274	(⊙)	⊙	⊙	⊙	⊙	
	12.5	12.375	110	380	4.87	1070	3800	3.1944	(⊙)	⊙	⊙	⊙	⊙	
	16.0	16.451	90	390	3.72	1110	4000	3.2491	(⊙)	⊙	⊙	⊙	⊙	
	20.0	19.362	70	390	3.19	1110	4200	2.9048	(⊙)	⊙	⊙	⊙		
	25.0	25.255	55	395	2.48	1150	4500	2.3847	(⊙)	⊙	⊙	⊙		
	31.5	33.214	45	400	1.68	1210	4700	2.2448	(⊙)	⊙	⊙	⊙		
	40	38.571	35	285	1.10	1380	4900	2.3551	(⊙)	⊙	⊙			
50	50.727	30	285	0.85	1390	5000	2.2276	(⊙)	⊙					
63	63.333	22	285	0.69	1400	5000	2.1571	(⊙)	⊙					
FRD 33 3c	40	38.063	35	420	1.68	100	4000	2.3849	(⊙)	⊙	⊙			
	50	48.772	30	420	1.33	350	4100	4.8227	(⊙)	⊙	⊙			
	63	64.836	22	420	1.01	580	4200	5.2165	(⊙)	⊙	⊙			
	80	76.310	18	420	0.87	690	4400	5.0177	(⊙)	⊙				
	100	99.535	14	425	0.67	830	4500	4.6787	(⊙)	⊙				
	125	130.903	11	425	0.51	870	4600	4.6625	(⊙)	⊙				
	160	167.799	9.0	425	0.40	850	4700	6.8317	(⊙)	⊙				
	200	197.495	7.0	425	0.34	900	4100	6.6412	(⊙)	⊙				
	250	257.602	5.5	430	0.26	930	4300	6.3012	(⊙)	⊙				
	315	307.214	4.5	430	0.22	950	4500	6.3065	(⊙)	⊙				
	400	393.429	3.5	290	0.11	1150	5000	6.3129	(⊙)					
	500	517.418	2.8	290	0.09	1170	5000	6.3038	(⊙)					
	630	646.000	2.2	290	0.07	1200	5000	6.2999	(⊙)					

2c, 3c - Number of reduction stages

⊙ - B5 and B14

(⊙) - B5 only

Lubrication (Oil litres) and Weights (kg)

	H	V	kg
FRD32	1.3	1.8	13.5
FRD33	1.6	2.1	14.5

RD Gearboxes

RD4 - 700 Nm

Speed Reducer Selection

1400 rpm

	i_n	i_r	n_2 [rpm]	M_2 [Nm]	P_1 [kW]	F_{r1} [N]	F_{r2} [N]	J_1 ($\times 10^{-4}$) [kgm ²]	71	80	90	100	112	132
FRD 42 2c	2.25	2.343	598	278	18.8	480	2000	22.729	(⊙)	⊙	⊙	⊙	⊙	⊙
	2.5	2.489	560	300	17.7	490	2300	18.663	(⊙)	⊙	⊙	⊙	⊙	⊙
	2.80	2.929	478	301	16.3	500	2400	16.454	(⊙)	⊙	⊙	⊙	⊙	⊙
	3.15	3.111	445	320	15.3	530	2500	14.976	(⊙)	⊙	⊙	⊙	⊙	⊙
	3.55	3.727	376	324	13.7	550	2600	13.145	(⊙)	⊙	⊙	⊙	⊙	⊙
	4.0	3.960	350	380	14.2	560	2700	12.317	(⊙)	⊙	⊙	⊙	⊙	⊙
	4.5	4.547	308	342	11.9	570	2800	12.115	(⊙)	⊙	⊙	⊙	⊙	⊙
	5.0	4.830	280	400	12.3	580	3000	10.808	(⊙)	⊙	⊙	⊙	⊙	⊙
	5.6	5.674	247	359	10.0	750	3000	12.483	(⊙)	⊙	⊙	⊙	⊙	⊙
	6.3	6.286	220	620	15.2	1000	3100	13.636	(⊙)	⊙	⊙	⊙	⊙	⊙
	7.1	7.321	191	329	7.1	1040	3300	12.434	(⊙)	⊙	⊙	⊙	⊙	⊙
	8.0	7.857	175	620	12.3	1070	3500	11.759	(⊙)	⊙	⊙	⊙	⊙	⊙
	9.0	9.124	153	282	4.9	1100	3600	10.943	(⊙)	⊙	⊙	⊙	⊙	⊙
	10.0	10.000	140	620	9.8	1140	3700	10.331	(⊙)	⊙	⊙	⊙	⊙	⊙
	12.5	12.199	110	620	8.0	1180	4600	9.4739	(⊙)	⊙	⊙	⊙	⊙	⊙
	16.0	15.223	90	650	6.6	1210	5700	8.7672	(⊙)	⊙	⊙	⊙	⊙	⊙
	20.0	19.643	70	650	5.7	1250	5800	8.1877	(⊙)	⊙	⊙	⊙	⊙	⊙
	25.0	24.478	55	650	4.2	1270	6000	7.8266	(⊙)	⊙	⊙	⊙	⊙	
	31.5	29.643	45	650	3.5	1280	6100	7.6050	(⊙)	⊙	⊙	⊙		
	40	41.538	35	450	1.5	1580	7000	7.7554	(⊙)	⊙	⊙			
50	50.303	30	450	1.2	1590	7500	7.5565	(⊙)	⊙	⊙				
63	62.963	22	450	1.1	1590	8000	7.3860	(⊙)	⊙	⊙				
FRD 43 3c	40	41.875	35	700	2.5	400	5000	7.5184	(⊙)	⊙	⊙	⊙		
	50	51.084	30	700	2.1	640	5100	9.8959	(⊙)	⊙	⊙	⊙		
	63	63.747	22	700	1.5	860	5200	10.279	(⊙)	⊙	⊙			
	80	82.254	18	700	1.7	1070	5200	10.062	(⊙)	⊙	⊙			
	100	102.502	14	700	1.1	1210	5300	9.7166	(⊙)	⊙	⊙			
	125	124.129	11	700	0.9	1310	5400	9.6972	(⊙)	⊙				
	160	160.689	9.0	700	0.7	1250	5500	11.857	(⊙)	⊙				
	200	207.341	7.0	700	0.6	1160	5600	11.663	(⊙)	⊙				
	250	258.379	5.5	700	0.4	1290	5800	11.324	(⊙)	⊙				
	315	312.297	4.5	700	0.35	1390	6000	11.326	(⊙)	⊙				
	400	438.462	3.5	460	0.22	1610	7000	11.333	(⊙)					
	500	530.976	2.8	460	0.12	1650	7500	11.324	(⊙)					
	630	664.609	2.2	460	0.11	1670	8000	11.319	(⊙)					

2c, 3c
⊙
(⊙)

- Number of reduction stages
- B5 and B14
- B5 only

Lubrication (Oil litres) and Weights (kg)

	H	V	kg
FRD42	2.2	3.0	20.0
FRD43	2.2	3.4	21.5

RD5 - 1300 Nm

Gearboxes RD

1400 rpm

Speed Reducer Selection

	i_n	i_r	n_2 [rpm]	M_2 [Nm]	P_1 [kW]	F_{r1} [N]	F_{r2} [N]	$J_1 (x 10^{-4})$ [kgm ²]	80	90	100	112	132	160	180
FRD 52 2c	2.25	2.323	603	574	39.1	720	3200	31.657	⊙	⊙	⊙	⊙	(⊙)	(⊙)	⊙
	2.5	2.5567	548	630	34	750	3400	26.128	⊙	⊙	⊙	⊙	(⊙)	(⊙)	⊙
	2.80	2.945	475	624	33.5	770	3500	24.154	⊙	⊙	⊙	⊙	(⊙)	(⊙)	⊙
	3.15	3.241	432	690	30	790	3700	20.966	⊙	⊙	⊙	⊙	(⊙)	(⊙)	⊙
	3.55	3.568	392	662	29.3	820	3900	18.578	⊙	⊙	⊙	⊙	(⊙)	(⊙)	⊙
	4.0	3.926	357	750	29	850	4000	17.244	⊙	⊙	⊙	⊙	(⊙)	(⊙)	⊙
	4.5	4.398	318	698	25.1	860	4300	16.421	⊙	⊙	⊙	⊙	(⊙)	(⊙)	⊙
	5.0	4.840	289	850	26.8	870	4500	15.131	⊙	⊙	⊙	⊙	(⊙)	(⊙)	⊙
	5.6	5.561	252	713	20.3	1100	4500	17.750	⊙	⊙	⊙	⊙	(⊙)	(⊙)	⊙
	6.3	6.454	217	1160	27.4	1500	4600	23.290	⊙	⊙	⊙	⊙	(⊙)	(⊙)	⊙
	7.1	7.305	192	630	13.6	1550	4800	18.351	⊙	⊙	⊙	⊙	(⊙)	(⊙)	⊙
	8.0	8.185	171	1170	21.8	1600	5200	16.463	⊙	⊙	⊙	⊙	(⊙)	(⊙)	⊙
	9.0	9.353	150	512	8.7	1650	5300	15.154	⊙	⊙	⊙	⊙	(⊙)	(⊙)	⊙
	10.0	9.915	141	1180	18.1	1700	5500	14.463	⊙	⊙	⊙	⊙	(⊙)	(⊙)	⊙
	12.5	12.222	115	1190	14.8	1780	6900	13.264	⊙	⊙	⊙	⊙	(⊙)	(⊙)	⊙
	16.0	15.452	91	1200	11.8	1820	8500	12.274	⊙	⊙	⊙	⊙	(⊙)	(⊙)	
	20.0	20.298	69	1220	9.1	1870	8700	11.463	⊙	⊙	⊙	⊙	(⊙)	(⊙)	
	25.0	25.989	54	1230	7.2	1900	9000	10.963	⊙	⊙	⊙	⊙	(⊙)		
	31.5	31.429	45	1240	6.0	1920	9100	10.647	⊙	⊙	⊙	⊙	(⊙)		
	40	40.476	35	850	3.2	2400	10500	10.858	⊙	⊙	⊙	⊙			
50	53.333	26	850	2.4	2450	11200	10.579	⊙	⊙	⊙	⊙				
63	66.667	21	850	1.9	2500	12000	10.340	⊙	⊙	⊙	⊙				
FRD 53 3c	40	39.333	36	1270	5.0	700	7600	10.526	⊙	⊙	⊙	⊙			
	50	47.984	29	1280	4.1	970	7800	13.854	⊙	⊙	⊙	⊙			
	63	59.878	23	1290	3.4	1290	7800	14.391	⊙	⊙	⊙	⊙			
	80	77.262	18	1300	2.6	1610	7900	14.087	⊙	⊙	⊙	⊙			
	100	96.280	15	1300	2.1	1820	7900	13.603	⊙	⊙	⊙	⊙			
	125	129.800	11	1300	1.6	1980	8100	13.576	⊙	⊙					
	160	157.143	8.9	1300	1.3	1450	8200	16.600	⊙	⊙					
	200	195.824	7.1	1300	1.1	1750	8400	16.328	⊙	⊙					
	250	264.000	5.3	1300	0.8	1930	8700	15.854	⊙	⊙					
	315	332.308	4.2	900	0.45	2100	9000	15.857	⊙	⊙					
	400	402.424	3.5	900	0.35	2400	10500	15.866	⊙	⊙					
	500	503.704	2.8	900	0.3	2500	11200	15.854	⊙	⊙					
	630	629.630	2.2	900	0.25	2550	12000	15.847	⊙	⊙					

2c, 3c - Number of reduction stages
 ⊙ - B5 only
 (⊙) - B5 and B14

Lubrication (Oil litres) and Weights (kg)

	H	V	kg
FRD52	4.5	5.5	49
FRD53	4.5	6.5	52

RD Gearboxes

RD6 - 2300 Nm

Speed Reducer Selection

1400 rpm

	i_n	i_r	n_2 [rpm]	M_2 [Nm]	P_1 [kW]	F_{r1} [N]	F_{r2} [N]	$J_1 (x 10^{-4})$ [kgm ²]	80	90	100	112	132	160	180
FRD 62 2c	2.25	2.323	603	1149	78.2	1100	4800	85.205	⊙	⊙	⊙	⊙	(⊙)	(⊙)	⊙
	2.5	2.616	535	1300	70.0	1100	5100	67.187	⊙	⊙	⊙	⊙	(⊙)	(⊙)	⊙
	2.80	2.945	475	1249	67.0	1100	5400	58.515	⊙	⊙	⊙	⊙	(⊙)	(⊙)	⊙
	3.15	3.318	422	1400	60.0	1150	5600	53.914	⊙	⊙	⊙	⊙	(⊙)	(⊙)	⊙
	3.55	3.568	392	1324	58.7	1200	5800	49.394	⊙	⊙	⊙	⊙	(⊙)	(⊙)	⊙
	4.0	4.019	348	1600	58.0	1220	6000	44.341	⊙	⊙	⊙	⊙	(⊙)	(⊙)	⊙
	4.5	4.398	318	1399	50.3	1250	6400	42.724	⊙	⊙	⊙	⊙	(⊙)	(⊙)	⊙
	5.0	4.955	283	1800	55.4	1270	6700	38.909	⊙	⊙	⊙	⊙	(⊙)	(⊙)	⊙
	5.6	5.561	252	1427	40.6	1500	6800	42.780	⊙	⊙	⊙	⊙	(⊙)	(⊙)	⊙
	6.3	6.571	213	2000	46.8	2180	6900	59.890	⊙	⊙	⊙	⊙	(⊙)	(⊙)	⊙
	7.1	7.305	192	1261	27.3	2200	7200	45.425	⊙	⊙	⊙	⊙	(⊙)	(⊙)	⊙
	8.0	8.333	168	2000	36.6	2340	7800	42.332	⊙	⊙	⊙	⊙	(⊙)	(⊙)	⊙
	9.0	8.700	161	1145	20.8	2400	8000	40.422	⊙	⊙	⊙	⊙	(⊙)	(⊙)	⊙
	10.0	10.095	139	2100	31.7	2500	8300	37.192	⊙	⊙	⊙	⊙	(⊙)	(⊙)	⊙
	12.5	12.444	113	2100	25.7	2600	10300	34.106	⊙	⊙	⊙	⊙	(⊙)	(⊙)	⊙
	16.0	15.733	89	2100	20.3	2650	12800	31.562	⊙	⊙	⊙	⊙	(⊙)	(⊙)	⊙
	20.0	20.667	68	2100	15.5	2700	13000	29.477	⊙	⊙	⊙	⊙	(⊙)	(⊙)	⊙
	25.0	24.615	57	2100	13.0	2750	13500	28.188	⊙	⊙	⊙	⊙	(⊙)		
	31.5	33.200	42	2220	10.0	2850	13700	27.378	⊙	⊙	⊙	⊙	(⊙)		
	40	40.500	35	1600	6.0	3400	15700	27.919	⊙	⊙	⊙	⊙	(⊙)		
50	49.800	28	1600	4.9	3450	16800	27.203	⊙	⊙	⊙	⊙	(⊙)			
63	56.000	25	1600	4.3	3500	18000	26.590	⊙	⊙	⊙	⊙	(⊙)			
FRD 63 3c	40	39.708	35	2200	8.6	900	11400	27.066	⊙	⊙	⊙	⊙	(⊙)		
	50	48.948	29	2200	7.0	1400	11700	35.625	⊙	⊙	⊙	⊙	(⊙)		
	63	61.884	23	2200	5.5	1870	11700	37.004	⊙	⊙	⊙	⊙	(⊙)		
	80	81.289	17	2300	4.4	2400	11900	36.223	⊙	⊙	⊙	⊙	(⊙)		
	100	104.082	13	2300	3.7	2600	11900	34.980	⊙	⊙	⊙	⊙			
	125	125.867	11	2300	3.4	2800	12000	34.910	⊙	⊙	⊙	⊙			
	160	157.333	9	2300	2.8	2100	12300	42.685	⊙	⊙	⊙	⊙			
	200	201.571	6.9	2300	1.8	2500	12600	41.987	⊙	⊙	⊙	⊙			
	250	265.600	5.3	2300	1.4	2800	13000	40.766	⊙	⊙					
	315	332.000	4.2	2300	1.1	3000	13500	40.774	⊙	⊙					
	355	373.333	3.1	2300	1.6	3500	15700	40.799	⊙	⊙					
	450	448.000	3.1	2300	0.8	3600	16800	40.766	⊙	⊙					
	560	560.000	2.5	2300	0.7	3700	18000	40.748	⊙	⊙					

2c & 3c - Number of reduction stages
 ⊙ - B5 only
 (⊙) - B5 and B14

Lubrication (Oil litres) and Weights (kg)

	H	V	kg
FRD62	7.0	9.0	62
FRD63	7.0	11	70

MRD

Gearboxes RD

1400 rpm

Geared Motor Selection

P ₁ [kW]	i _n	i _r	N ₂ [rpm]	M ₂ [Nm]	FS	Size	F _{r2} [N]	MRD [kg]	FRD [kg]	J _m × 10 ⁻⁴	J ₁ × 10 ⁻⁴
0,06	2,5	2,57	530	1,0	>3,5	MRD02	820	5,5	3,0	1,50	0,4044
	3,15	3,28	415	1,3	>3,5	MRD02	890	5,5	3,0	1,50	0,3235
	4,0	4,26	320	1,7	>3,5	MRD02	960	5,5	3,0	1,50	0,2677
	5,0	5,28	258	2,1	>3,5	MRD02	1020	5,5	3,0	1,50	0,2380
	6,3	6,25	217	2,5	>3,5	MRD02	1100	5,5	3,0	1,50	0,3088
	8,0	7,98	170	3,2	>3,5	MRD02	1180	5,5	3,0	1,50	0,2649
	10,0	10,36	131	4,2	>3,5	MRD02	1290	5,5	3,0	1,50	0,2329
	12,5	12,84	106	5,2	>3,5	MRD02	1370	5,5	3,0	1,50	0,2153
	16,0	16,32	83	6,6	>3,5	MRD02	1480	5,5	3,0	1,50	0,2010
	20,0	21,53	63	8,7	>3,5	MRD02	1590	5,5	3,0	1,50	0,1899
	25,0	26,75	51	10,8	>3,5	MRD02	1590	5,5	3,0	1,50	0,1837
	31,5	30,22	45	12,2	>3,5	MRD02	1580	5,5	3,0	1,50	0,1812
	35,5	34,68	40	13,9	>3,5	MRD02	1580	5,5	3,0	1,50	0,1881
	40	43,07	32	17,4	2,01	MRD02	1560	5,5	3,0	1,50	0,1826
		36,89	37	14,9	3,48	MRD03	1570	5,7	3,2	1,50	0,1530
	50	48,67	28	19,7	1,83	MRD02	1550	5,5	3,0	1,50	0,1803
		47,07	29	19,0	2,73	MRD03	1560	5,7	3,2	1,50	0,4897
	63	61,14	22	24,7	2,10	MRD03	1520	5,7	3,2	1,50	0,4807
		61,67	22	25,0	2,81	MRD12	1960	7,0	4,5	1,50	0,6681
	80	75,78	18	30,7	1,70	MRD03	1480	5,7	3,2	1,50	0,4764
		80,43	17	33	3,07	MRD13	1930	7,2	4,7	1,50	1,2905
	100	96,29	14	38,9	1,34	MRD03	1400	5,7	3,2	1,50	0,4735
		100,60	14	41	2,45	MRD13	1900	7,2	4,7	1,50	1,2861
	125	127,05	10,7	51,4	1,01	MRD03	1230	5,7	3,2	1,50	0,4717
		130,84	10,4	53	1,89	MRD13	1820	7,2	4,7	1,50	1,2833
	160	157,81	8,6	63,8	0,81	MRD03	970	5,7	3,2	1,50	0,4709
		165,08	8,2	67	1,50	MRD13	1710	7,2	4,7	1,50	1,7033
	180	178,31	7,6	72,1	0,80	MRD03	700	5,7	3,2	1,50	0,4706
	200	204,58	6,6	45,0	0,80	MRD03	1300	5,7	3,2	1,50	0,4716
		206,46	6,6	84	1,20	MRD13	1530	7,2	4,7	1,50	1,6996
	250	254,11	5,4	45,0	0,80	MRD03	1300	5,7	3,2	1,50	0,4709
	268,54	5,1	109	0,92	MRD13	1100	7,2	4,7	1,50	1,6974	
280	287,13	4,7	45,0	0,80	MRD03	1300	5,7	3,2	1,50	0,4706	
315	324,44	4,2	45,0	0,80	MRD03	1300	5,7	3,2	1,50	0,4927	
0,09	2,5	2,57	530	1,6	>3,5	MRD02	810	5,6	3,0	2,00	0,4044
	3,15	3,28	415	2,0	>3,5	MRD02	880	5,6	3,0	2,00	0,3235
	4,0	4,26	320	2,6	>3,5	MRD02	950	5,6	3,0	2,00	0,2677
	5,0	5,28	258	3,2	>3,5	MRD02	1010	5,6	3,0	2,00	0,2380
	6,3	6,25	217	3,8	>3,5	MRD02	1080	5,6	3,0	2,00	0,3088
	8,0	7,98	170	4,8	>3,5	MRD02	1170	5,6	3,0	2,00	0,2649
	10,0	10,36	131	6,3	>3,5	MRD02	1270	5,6	3,0	2,00	0,2329
	12,5	12,84	106	7,8	>3,5	MRD02	1350	5,6	3,0	2,00	0,2153
	16,0	16,32	83	9,9	>3,5	MRD02	1450	5,6	3,0	2,00	0,2010
	20,0	21,53	63	13,1	>3,5	MRD02	1570	5,6	3,0	2,00	0,1899
	25,0	26,75	51	16,2	3,20	MRD02	1570	5,6	3,0	2,00	0,1837
	31,5	30,22	45	18,3	2,84	MRD02	1560	5,6	3,0	2,00	0,1812
	35,5	34,68	40	20,9	1,68	MRD02	1540	5,6	3,0	2,00	0,1881
	40	43,07	32	26,1	1,34	MRD02	1510	5,6	3,0	2,00	0,1826
		36,89	37	22,4	2,32	MRD03	1540	5,8	3,2	2,00	0,1530
		39,08	35	23,7	2,95	MRD12	1940	7,0	4,4	2,00	0,6890

RD Gearboxes

MRD

Geared Motor Selection

1400 rpm

P ₁ [kW]	i _n	i _r	N ₂ [rpm]	M ₂ [Nm]	FS	Size	F _{r2} [N]	MRD [kg]	FRD [kg]	J _m × 10 ⁻⁴	J ₁ × 10 ⁻⁴
0.09	50	48,67	28	29,5	1,22	MRD02	1490	5,6	3,0	2,00	0,1803
		47,07	29	28,6	1,82	MRD03	1500	5,8	3,2	2,00	0,4897
		48,12	28	29,2	2,40	MRD12	1940	7,0	4,4	2,00	0,6776
		52,20	26	32	3,12	MRD13	1940	7,2	4,6	2,00	1,3094
	63	61,14	22	37,1	1,40	MRD03	1420	5,8	3,2	2,00	0,4807
		61,67	22	37	1,88	MRD12	1900	7,1	4,5	2,00	0,6681
		66,03	21	40	2,50	MRD13	1900	7,3	4,7	2,00	1,2967
	80	75,78	18	46,0	1,13	MRD03	1310	5,8	3,2	2,00	0,4764
		80,43	17	49	2,05	MRD13	1850	7,3	4,7	2,00	1,2905
	100	96,29	14	58,4	0,89	MRD03	1100	5,8	3,2	2,00	0,4735
		100,60	14	61	1,64	MRD13	1760	7,3	4,7	2,00	1,2861
		125	130,84	10,4	79	1,26	MRD13	1580	7,3	4,7	2,00
	160	165,08	8,2	100	1,00	MRD13	1280	7,3	4,7	2,00	1,7033
		200	206,46	6,6	125	0,80	MRD13	1000	7,3	4,7	2,00
0.13	2,5	2,57	530	2,1	>3,5	MRD02	810	6,8	3,1	2,80	0,5356
	3,15	3,28	415	2,7	>3,5	MRD02	870	6,8	3,1	2,80	0,4548
	4,0	4,26	320	3,4	>3,5	MRD02	940	6,8	3,1	2,80	0,3989
	5,0	5,28	258	4,3	>3,5	MRD02	1000	6,8	3,1	2,80	0,3692
	6,3	6,25	217	5,1	>3,5	MRD02	1070	6,8	3,1	2,80	0,4401
	8,0	7,98	170	6,5	>3,5	MRD02	1160	6,8	3,1	2,80	0,3961
	10,0	10,36	131	8,4	>3,5	MRD02	1250	6,8	3,1	2,80	0,3641
	12,5	12,84	106	10,4	>3,5	MRD02	1330	6,8	3,1	2,80	0,3466
	16,0	16,32	83	13,2	>3,5	MRD02	1420	6,8	3,1	2,80	0,3323
	20,0	21,53	63	17,4	2,93	MRD02	1530	6,8	3,1	2,80	0,3211
	25,0	26,75	51	21,6	2,40	MRD02	1550	6,8	3,1	2,80	0,3150
	31,5	30,22	45	24,4	2,13	MRD02	1530	6,8	3,1	2,80	0,3124
	35,5	34,68	40	27,8	1,26	MRD02	1510	6,8	3,1	2,80	0,3194
	40	43,07	32	34,8	1,00	MRD02	1450	6,8	3,1	2,80	0,3138
		36,89	37	29,8	1,74	MRD03	1500	7,0	3,3	2,80	0,1499
		39,08	35	32	2,21	MRD12	1910	8,3	4,6	2,80	0,6867
		40,10	34	32	3,05	MRD13	1940	8,4	4,7	2,80	0,4521
	50	48,67	28	39,4	0,91	MRD02	1410	6,8	3,1	2,80	0,3115
		47,07	29	38,1	1,37	MRD03	1430	7,0	3,3	2,80	0,4865
		48,12	28	39	1,80	MRD12	1910	8,3	4,6	2,80	0,6753
		52,20	26	42	2,34	MRD13	1900	8,4	4,7	2,80	1,4775
	63	61,14	22	49,5	1,05	MRD03	1300	7,0	3,3	2,80	0,4775
		61,67	22	50	1,41	MRD12	1850	8,4	4,7	2,80	0,6658
		66,03	21	53	1,87	MRD13	1840	8,5	4,8	2,80	1,4648
	80	75,78	18	61,3	0,85	MRD03	1100	7,0	3,3	2,80	0,4733
		80,43	17	65	1,54	MRD13	1750	8,5	4,8	2,80	1,4586
		81,52	16,7	66	3,03	MRD23	3300	26,3	12,8	2,80	2,0939
	100	100,60	14	81	1,23	MRD13	1600	8,5	4,8	2,80	1,4542
		105,43	12,9	85	2,34	MRD23	3250	26,6	13,1	2,80	2,0832
	125	130,84	10,4	106	0,94	MRD13	1270	8,5	4,8	2,80	1,4513
		124,16	11,0	100	1,99	MRD23	3150	27,2	13,7	2,80	2,0798
160	165,08	8,2	134	0,75	MRD13	1100	8,5	4,8	2,80	1,8714	
	164,94	8,2	133	1,50	MRD23	2950	32,4	18,9	2,80	2,6601	
	209,25	6,5	169	1,18	MRD23	2650	27,2	13,7	2,80	2,6491	
250	270,63	5,0	219	0,91	MRD23	1980	33,5	20,0	2,80	2,6418	
315	318,70	4,3	258	0,78	MRD23	1600	33,6	20,1	2,80	2,6399	

MRD

Gearboxes RD

1400 rpm

Geared Motor Selection

P ₁ [kW]	i _n	i _r	N ₂ [rpm]	M ₂ [Nm]	FS	Size	F _{r2} [N]	MRD [kg]	FRD [kg]	J _m × 10 ⁻⁴	J ₁ × 10 ⁻⁴	
0.18	2,5	2,57	533	3,1	>3,5	MRD02	800	7,4	3,1	4,00	0,5356	
	3,15	3,28	4,0018	3,9	>3,5	MRD02	860	7,4	3,1	4,00	0,4548	
	4,0	4,26	322	5,1	>3,5	MRD02	920	7,4	3,1	4,00	0,3989	
	5,0	5,28	260	6,4	>3,5	MRD02	980	7,4	3,1	4,00	0,3692	
	6,3	6,25	219	7,5	>3,5	MRD02	1050	7,4	3,1	4,00	0,4401	
	8,0	7,98	172	9,6	>3,5	MRD02	1130	7,4	3,1	4,00	0,3961	
	10,0	10,36	132	12,5	>3,5	MRD02	1210	7,4	3,1	4,00	0,3641	
	12,5	12,84	107	15,5	3,23	MRD02	1280	7,4	3,1	4,00	0,3466	
	16,0	16,32	84	19,7	2,59	MRD02	1360	7,4	3,1	4,00	0,3323	
	20,0	21,53	64	25,9	1,97	MRD02	1460	7,4	3,1	4,00	0,3211	
	25,0	26,75	51	32,2	1,61	MRD02	1480	7,4	3,1	4,00	0,3150	
			26,52	51	32	2,90	MRD12	1940	8,9	4,6	4,00	0,6894
	31,5	30,22	45	36,4	1,43	MRD02	1440	7,4	3,1	4,00	0,3124	
			32,65	42	40	2,38	MRD12	1910	8,9	4,6	4,00	0,6771
	35,5	34,68	40	41,8	0,84	MRD02	1390	7,4	3,1	4,00	0,3194	
	40	36,89	37	44,4	1,17	MRD03	1370	7,6	3,3	4,00	0,1499	
			39,08	35	47	1,48	MRD12	1800	8,9	4,6	4,00	0,6867
			40,10	34	49	2,03	MRD13	1870	9,0	4,7	4,00	0,4521
	50	47,07	29	56,7	0,92	MRD03	1200	7,6	3,3	4,00	0,4865	
			48,12	28	58	1,20	MRD12	1800	8,9	4,6	4,00	0,6753
			52,20	26	63	1,56	MRD13	1770	9,0	4,7	4,00	1,4775
			52,17	26,1	63	3,15	MRD23	3330	34,0	18,5	4,00	2,1312
	63	61,14	22	73,6	0,80	MRD03	800	7,6	3,3	4,00	0,4775	
			61,67	22	75	0,94	MRD12	1670	9,0	4,7	4,00	0,6658
			66,03	21	80	1,25	MRD13	1630	9,1	4,8	4,00	1,4648
			64,26	21,2	78	2,57	MRD23	3280	35,5	20,0	4,00	2,1092
	80	80,43	17	98	1,02	MRD13	1420	9,1	4,8	4,00	1,4586	
			81,52	16,7	99	2,02	MRD23	3190	35,7	20,2	4,00	2,0939
	100	100,60	14	122	0,82	MRD13	1200	9,1	4,8	4,00	1,4542	
			105,43	12,9	128	1,56	MRD23	3000	26,6	7,6	4,00	2,0832
	125	124,16	11,0	151	1,33	MRD23	2850	26,6	7,6	4,00	2,0798	
	160	164,94	8,2	200	1,00	MRD23	2280	26,6	7,6	4,00	2,6601	
200	209,25	6,5	254	0,79	MRD23	1500	32,1	13,1	4,00	2,6491		
0.25	2,5	2,57	533	4,3	>3,5	MRD02	780	9,0	3,2	5,00	0,5251	
	3,15	3,28	418	5,5	>3,5	MRD02	840	9,0	3,2	5,00	0,4443	
	4,0	4,26	322	7,1	>3,5	MRD02	900	9,0	3,2	5,00	0,3587	
	5,0	5,28	260	8,8	>3,5	MRD02	960	9,0	3,2	5,00	0,3587	
	6,3	6,25	219	10,5	>3,5	MRD02	1020	9,0	3,2	5,00	0,4296	
	8,0	7,98	172	13,3	>3,5	MRD02	1100	9,0	3,2	5,00	0,3856	
	10,0	10,36	132	17,3	2,88	MRD02	1170	9,0	3,2	5,00	0,3536	
	12,5	12,84	107	21,5	2,33	MRD02	1230	9,0	3,2	5,00	0,3361	
	16,0	16,32	84	27,3	1,87	MRD02	1300	9,0	3,2	5,00	0,3218	
			16,30	85	27	3,36	MRD12	1960	10,5	4,7	5,00	0,7295
	20,0	21,53	64	36,0	1,42	MRD02	1370	9,0	3,2	5,00	0,3106	
			20,39	68	34	2,72	MRD12	1930	10,5	4,7	5,00	0,7019
	25,0	26,75	51	44,7	1,16	MRD02	1370	9,0	3,2	5v	0,3045	
			26,52	52	44	2,12	MRD12	1890	10,5	4,7	5,00	0,6796
	31,5	32,65	42	54	1,74	MRD12	1840	10,5	4,7	5,00	0,6672	
	40	36,89	37	61,7	0,84	MRD03	1140	9,2	3,4	5,00	0,1763	
			39,08	35	65	1,08	MRD12	1630	10,5	4,7	5,00	0,6769

RD Gearboxes

MRD

Geared Motor Selection

1400 rpm

P ₁ [kW]	i _n	i _r	N ₂ [rpm]	M ₂ [Nm]	FS	Size	F _{r2} [N]	MRD [kg]	FRD [kg]	J _m × 10 ⁻⁴	J ₁ × 10 ⁻⁴
0.25	40	40,10	34	67	1,49	MRD13	1750	10,6	4,8	5,00	0,4422
		39,39	35	65	2,11	MRD22	3320	13,5	7,7	5,00	1,2877
		40,76	34	68	2,94	MRD23	2000	13,9	8,1	5,00	1,3104
	50	48,12	29	80	0,88	MRD12	1630	10,5	4,7	5,00	0,6654
		52,20	26	87	1,14	MRD13	1580	10,6	4,8	5,00	1,4676
		50,76	27	84	1,64	MRD22	3250	13,5	7,7	5,00	1,3030
		52,17	26	87	2,30	MRD23	3250	14,0	8,2	5,00	2,1312
		50,73	27	84	3,37	MRD32	7950	19,1	13,3	5,00	1,8570
	63	66,03	21	110	0,91	MRD13	1260	10,7	4,9	5,00	1,4549
		62,13	22	103	1,35	MRD22	3170	13,6	7,8	5,00	1,2810
		64,26	21	107	1,87	MRD23	3150	14,0	8,2	5,00	2,1092
		63,33	22	105	2,71	MRD32	7850	19,1	13,3	5,00	1,7865
	80	80,43	17	134	0,75	MRD13	1020	10,7	4,9	5,00	1,4487
		81,52	17	135	1,48	MRD23	2950	14,0	8,2	5,00	2,0939
		76,31	18	127	3,33	MRD33	7800	20,1	14,3	5,00	4,6584
	100	105,43	13	175	1,14	MRD23	2650	14,0	8,2	5,00	2,0832
		99,54	14	165	2,56	MRD33	7600	20,2	14,4	5,00	4,3194
		125	124,16	11	206	0,97	MRD23	2250	14,0	8,2	5,00
	160	130,90	10,5	217	1,95	MRD33	7200	20,2	14,4	5,00	4,3033
		128,71	10,7	214	2,95	MRD43	7700	28,2	9,2	5,00	6,6730
		164,94	8,4	274	0,73	MRD23	2000	14,0	8,2	5,00	2,6601
		167,80	8,2	279	1,53	MRD33	6500	20,2	14,4	5,00	6,4724
		157,36	8,8	261	2,68	MRD43	9800	33,8	14,8	5,00	8,8326
	200	197,50	7,0	328	1,30	MRD33	5900	20,2	14,4	5,00	6,2820
		206,95	6,7	344	1,84	MRD43	9600	33,8	14,8	5,00	8,6391
	250	257,60	5,4	428	1,00	MRD33	3600	20,3	14,5	5,00	5,9420
		258,38	5,3	429	1,63	MRD43	9100	28,3	9,3	5,00	8,2999
	315	307,21	4,5	510	0,84	MRD33	2700	20,3	14,5	5,00	5,9472
		318,46	4,3	529	1,37	MRD43	8000	39,6	20,6	5,00	8,3020
	0.37	2,5	2,57	537	6,3	>3,5	MRD02	760	9,4	3,2	8,00
3,15		3,28	421	8,1	>3,5	MRD02	820	9,4	3,2	8,00	0,4443
4,0		4,26	324	10,5	3,44	MRD02	870	9,4	3,2	8,00	0,3587
5,0		5,28	260	13,1	2,91	MRD02	920	9,4	3,2	8,00	0,3587
6,3		6,25	221	15,4	3,12	MRD02	980	9,4	3,2	8,00	0,4296
8,0		7,98	173	19,6	2,50	MRD02	1040	9,4	3,2	8,00	0,3856
10,0		10,36	133	25,5	1,96	MRD02	1100	9,4	3,2	8,00	0,3536
		10,58	130	26	3,42	MRD12	1960	10,8	4,6	8,00	0,8159
12,5		12,84	107	31,6	1,62	MRD02	1140	9,4	3,2	8,00	0,3361
		13,38	103	33	2,74	MRD12	1940	10,8	4,6	8,00	0,7619
16,0		16,32	85	40,1	1,27	MRD02	1180	9,4	3,2	8,00	0,3218
		16,30	85	40	2,27	MRD12	1910	10,9	4,7	8,00	0,7295
20,0		21,53	64	52,9	0,96	MRD02	1220	9,4	3,2	8,00	0,3106
		20,39	68	50	1,84	MRD12	1860	10,9	4,7	8,00	0,7019
25,0		26,75	52	65,7	0,80	MRD02	1020	9,4	3,2	8,00	0,3045
		26,52	52	65	1,43	MRD12	1760	10,9	4,7	8,00	0,6796
		26,73	52	66	2,85	MRD22	3320	13,8	7,6	8,00	1,3507
31,5		32,65	42	80	1,17	MRD12	1630	10,9	4,7	8,00	0,6672
		31,48	44	77	2,44	MRD22	3280	13,8	7,6	8,00	1,3210
40		39,08	35	96	0,73	MRD12	1630	10,9	4,7	8,00	0,6769
		40,10	34	99	1,00	MRD13	1580	11,0	4,8	8,00	0,4422

MRD

Gearboxes RD

1400 rpm

Geared Motor Selection

P ₁ [kW]	i _n	i _r	N ₂ [rpm]	M ₂ [Nm]	FS	Size	F _{r2} [N]	MRD [kg]	FRD [kg]	J _m × 10 ⁻⁴	J ₁ × 10 ⁻⁴
0.37	40	39,39	35	97	1,43	MRD22	3200	13,9	7,7	8,00	1,2877
		40,76	34	100	1,99	MRD23	2000	14,3	8,1	8,00	1,3104
		38,57	36	95	2,99	MRD32	7900	19,5	13,3	8,00	1,9845
	50	52,20	26	128	0,77	MRD13	1500	11,0	4,8	8,00	1,4676
		50,76	27	125	1,11	MRD22	3040	13,9	7,7	8,00	1,3030
		52,17	26	128	1,56	MRD23	2800	14,4	8,2	8,00	2,1312
	63	50,73	27	125	2,28	MRD32	7800	19,5	13,3	8,00	1,8570
		62,13	22	153	0,91	MRD22	2820	14,0	7,8	8,00	1,2810
		64,26	21	158	1,27	MRD23	2350	14,4	8,2	8,00	2,1092
	80	63,33	22	156	1,83	MRD32	7600	19,5	13,3	8,00	1,7865
		64,84	21	159	2,64	MRD33	7600	20,5	14,3	8,00	4,8573
		81,52	17	200	1,00	MRD23	1500	14,4	8,2	8,00	2,0939
	100	76,31	18	188	2,25	MRD33	7400	20,5	14,3	8,00	4,6584
		82,25	18,4	184	3,80	MRD43	9900	43,4	14,4	8,00	7,0373
		105,43	13	259	0,77	MRD23	1200	14,4	8,2	8,00	2,0832
	125	99,54	14	245	1,73	MRD33	6900	20,6	14,4	8,00	4,3194
		102,50	14,1	241	2,90	MRD43	9800	43,5	14,5	8,00	6,6923
		130,90	10,5	322	1,32	MRD33	6000	20,6	14,4	8,00	4,3033
	160	124,13	10,7	316	2,21	MRD43	7700	41,0	12,0	8,00	6,6730
		167,80	8,2	413	1,03	MRD33	4100	20,6	14,4	8,00	6,4724
		160,69	8,8	387	1,80	MRD43	9400	43,7	14,7	8,00	8,8326
200	197,50	7,0	486	0,88	MRD33	3500	20,6	14,4	8,00	6,2820	
	207,34	6,7	509	1,37	MRD43	8100	43,8	14,8	8,00	8,6391	
	258,38	5,3	635	1,10	MRD43	6000	49,4	20,4	8,00	8,2999	
315	312,90	4,3	783	0,90	MRD43	5000	43,8	14,8	8,00	8,3020	
0.55	2,5	2,57	541	9,3	3,22	MRD02	730	11,5	3,0	14	0,6362
	3,15	3,28	424	11,9	2,78	MRD02	780	11,5	3,0	14	0,5554
	4,0	4,26	327	15,4	2,33	MRD02	820	11,5	3,0	14	0,4995
		4,01	344	14,7	3,39	MRD12	1889	13,3	4,8	14	1,2685
	5,0	5,28	262	19,3	1,97	MRD02	870	11,5	3,0	14	0,4698
		5,07	272	18,5	2,85	MRD12	1980	13,3	4,8	14	1,1726
	6,3	6,25	222	22,7	2,12	MRD02	910	11,5	3,0	14	0,5407
		8,0	7,98	174	28,9	1,69	MRD02	960	11,5	3,0	14
	10,0		8,13	170	30	2,96	MRD12	1950	13,4	4,9	14
		12,5	10,36	134	37,6	1,33	MRD02	980	11,5	3,0	14
	16,0		10,58	130	39	2,30	MRD12	1920	13,4	4,9	14
		20,0	12,84	108	46,6	1,07	MRD02	1010	11,5	3,0	14
	25,0		13,38	103	49	1,84	MRD12	1870	13,4	4,9	14
		31,5	16,32	85	59,2	0,86	MRD02	1010	11,5	3,0	14
	40		16,30	85	60	1,53	MRD12	1800	13,5	5,0	14
		50	16,29	85	60	3,07	MRD22	3253	16,4	7,9	14
	63		20,39	68	75	1,23	MRD12	1660	13,5	5,0	14
		80	20,67	67	76	2,45	MRD22	3290	16,4	7,9	14
	100		26,52	52	97	0,96	MRD12	1430	13,5	5,0	14
		125	26,73	52	98	1,92	MRD22	3200	16,4	7,9	14
	160		32,65	42	119	0,79	MRD12	1020	13,5	5,0	14
200		31,48	44	115	1,64	MRD22	3100	16,4	7,9	14	1,8236
	250	33,21	42	121	3,30	MRD32	7800	21,8	13,3	14	2,3727
315		39,39	35	144	0,96	MRD22	2900	16,5	8,0	14	1,7903
		40,76	34	149	1,34	MRD23	1870	16,9	8,4	14	1,7099

RD Gearboxes

MRD

Geared Motor Selection

1400 rpm

P ₁ [kW]	i _n	i _r	N ₂ [rpm]	M ₂ [Nm]	FS	Size	F _{r2} [N]	MRD [kg]	FRD [kg]	J _m × 10 ⁻⁴	J ₁ × 10 ⁻⁴	
0.55	40	38,57	36	141	2,01	MRD32	7700	22,1	13,6	14	2,4830	
		41,54	33	152	2,96	MRD42	10700	28,8	20,3	14	4,5875	
		38,06	36	139	3,01	MRD33	1940	23,0	14,5	14	2,5282	
	50	50,76	27	186	0,75	MRD22	2700	16,5	8,0	14	1,8056	
		52,17	26	191	1,05	MRD23	2450	17,0	8,5	14	2,5308	
		50,73	27	185	1,53	MRD32	7400	22,1	13,6	14	2,3555	
	50,30	50,30	27	184	2,20	MRD42	10600	28,8	20,3	14	4,3886	
		48,77	28	178	2,36	MRD33	7500	23,0	14,5	14	4,8058	
		63	64,26	21	235	0,85	MRD23	1800	17,0	8,5	14	2,5088
	63	63,33	22	231	1,23	MRD32	7000	22,1	13,6	14	2,2850	
		62,96	22	230	1,95	MRD42	10300	28,9	20,4	14	4,2181	
		64,84	21	237	1,78	MRD33	7000	23,1	14,6	14	4,8220	
	63,75	63,75	21,6	233	2,69	MRD43	9800	30,0	21,5	14	7,2550	
		66,67	20,8	242	3,51	MRD52	12000	57,5	49	14	10,340	
		80	76,31	18	279	1,51	MRD33	6500	23,1	14,6	14	4,9660
	80	82,25	18,4	274	2,55	MRD43	9700	30,1	21,6	14	7,0373	
		100	99,54	14	364	1,16	MRD33	5200	23,2	14,7	14	5,1610
		102,50	14,1	358	1,95	MRD43	9500	30,3	21,8	14	6,6923	
	125	130,90	10,5	478	0,89	MRD33	4200	23,2	14,7	14	5,3598	
		124,13	10,7	470	1,49	MRD43	7200	30,4	21,9	14	6,6730	
		129,80	10,7	461	2,82	MRD53	8100	60,5	52	14	13,576	
	160	160,69	8,8	575	1,21	MRD43	7000	30,2	21,7	14	8,8326	
		157,14	8,8	558	2,33	MRD53	8200	60,5	52	14	16,600	
		200	207,34	6,7	756	0,92	MRD43	9000	30,3	21,8	14	8,6391
	200	195,82	7,1	696	1,87	MRD53	8400	50,5	52	14	16,328	
		250	264,00	5,3	938	1,39	MRD53	8700	60,5	52	14	14,854
		265,50	5,2	943	2,44	MRD63	13000	78,5	70	14	40,766	
	315	332,31	4,2	1180	0,76	MRD53	9000	60,5	52	14	15,856	
		332,00	4,2	1179	1,95	MRD63	13500	78,5	70	14	40,774	
		355	373,33	3,7	1326	1,73	MRD63	15700	78,5	70	14	40,799
450	448,00	3,1	1591	1,45	MRD63	16800	78,5	70	14	40,766		
	560	560,00	2,5	1989	1,16	MRD63	18000	78,5	70	14	40,748	
	0.75	2,5	2,57	541	12,7	2,36	MRD02	700	12,8	3,0	17	0,6362
2,53			546	12,6	3,39	MRD12	1680	14,6	4,8	17	1,6146	
3,15		3,28	424	16,2	2,04	MRD02	730	12,8	3,0	17	0,5554	
		3,08	450	15,3	2,99	MRD12	1713	14,6	4,8	17	1,4326	
4,0		4,26	327	21,1	1,71	MRD02	760	12,8	3,0	17	0,4995	
		4,01	345	19,9	2,50	MRD12	1842	14,6	4,8	17	1,2685	
5,0		5,28	263	26,1	1,46	MRD02	810	12,8	3,0	17	0,4698	
		5,07	273	25	2,10	MRD12	1958	14,6	4,8	17	1,1726	
6,3		6,25	222	30,9	1,55	MRD02	840	12,8	3,0	17	0,5407	
		6,69	207	33	2,62	MRD12	1940	14,7	4,9	17	1,3350	
8,0		7,98	174	39,5	1,24	MRD02	860	12,8	3,0	17	0,4967	
		8,13	170	40	2,18	MRD12	1910	14,7	4,9	17	1,2435	
10,0		10,36	134	51,3	0,98	MRD02	860	12,8	3,0	17	0,4647	
		10,58	131	53	1,69	MRD12	1850	14,7	4,9	17	1,1569	
12,5		12,84	108	63,5	0,80	MRD02	850	12,8	3,0	17	0,4472	
		13,38	103	66	1,36	MRD12	1750	14,7	4,9	17	1,1028	
		13,23	105	66	2,76	MRD22	2970	17,6	7,8	17	2,1227	

MRD

Gearboxes RD

1400 rpm

Geared Motor Selection

P ₁ [kW]	i _n	i _r	N ₂ [rpm]	M ₂ [Nm]	FS	Size	F _{r2} [N]	MRD [kg]	FRD [kg]	J _m × 10 ⁻⁴	J ₁ × 10 ⁻⁴
0.75	16,0	16,30	85	81	1,12	MRD12	1620	14,8	5,0	17	1,0704
		16,29	85	81	2,26	MRD22	3120	17,7	7,9	17	2,0125
	20,0	20,39	68	101	0,91	MRD12	1360	14,8	5,0	17	1,0429
		20,67	67	103	1,80	MRD22	3170	17,7	7,9	17	1,9223
	25,0	26,52	52	132	0,71	MRD12	1380	14,8	5,0	17	0,6741
		26,73	52	133	1,41	MRD22	2980	17,7	7,9	17	1,8534
		25,26	55	125	3,15	MRD32	7550	23,1	13,3	17	2,5126
	31,5	31,48	44	156	1,21	MRD22	2790	17,7	7,9	17	1,8236
		33,21	42	165	2,43	MRD32	7350	23,1	13,3	17	2,3727
	40	39,39	35	196	0,71	MRD22	2600	17,8	8,0	17	1,7903
		40,76	34	202	0,98	MRD23	1750	18,2	8,4	17	1,7099
		38,57	36	192	1,48	MRD32	6800	23,4	13,6	17	2,4830
	40	41,54	33	206	2,18	MRD42	10480	30,1	20,3	17	4,5875
		38,06	36	189	2,22	MRD33	5000	24,3	14,5	17	2,5282
		37,42	37,0	186	3,76	MRD43	9900	31,2	21,4	17	4,4941
	50	52,17	27	259	0,77	MRD23	1500	18,3	8,5	17	2,5308
		50,73	27	252	1,13	MRD32	5950	23,4	13,6	17	2,3555
		50,30	28	250	2,41	MRD42	9500	30,1	20,3	17	4,3886
		48,77	28	242	1,74	MRD33	6900	24,3	14,5	17	4,8058
		47,95	28,9	238	2,94	MRD43	9800	31,2	21,4	17	6,8717
	63	53,33	26,1	264	3,22	MRD52	11200	58,8	49	17	10,579
		63,33	22	315	0,91	MRD32	5000	23,4	13,6	17	2,2850
		62,96	22	313	1,43	MRD42	8500	30,2	20,4	17	4,2181
		64,84	21	322	1,31	MRD33	5900	24,4	14,6	17	4,8220
		63,75	21,7	317	2,20	MRD43	9700	31,3	21,5	17	7,2550
	80	66,67	20,8	330	2,58	MRD52	12000	58,8	49	17	10,240
		76,31	18	379	1,11	MRD33	4900	24,4	14,6	17	4,9660
		75,03	18,5	373	1,87	MRD43	9200	31,4	21,6	17	7,0373
	100	77,26	18,0	374	3,47	MRD53	7900	61,8	52	17	14,087
		99,54	14	494	0,86	MRD33	3500	24,5	14,7	17	5,1610
		97,86	14,2	486	1,44	MRD43	8100	31,6	21,8	17	6,6923
	125	96,28	14,4	466	2,79	MRD53	7900	61,8	52	17	13,603
		124,13	10,8	639	1,10	MRD43	6000	31,7	21,9	17	6,6730
129,80		10,7	629	2,07	MRD53	8100	61,8	52	17	13,576	
160	160,69	8,8	781	0,9	MRD43	5000	31,5	21,7	17	8,8326	
	157,14	8,8	761	1,71	MRD53	8200	61,8	52	17	16,600	
	157,33	8,8	762	3,02	MRD63	12300	79,8	70	17	42,685	
200	195,82	7,1	949	1,37	MRD53	8400	61,8	52	17	13,328	
	201,57	6,9	976	2,36	MRD63	12600	79,8	70	17	41,987	
250	264,00	5,3	1279	1,02	MRD53	8700	61,8	52	17	15,854	
	265,50	5,2	1286	1,79	MRD63	13000	79,8	70	17	40,766	
315	332,00	4,2	1608	1,43	MRD63	13500	79,8	70	17	40,774	
355	373,33	3,7	1808	1,27	MRD63	15700	79,8	70	17	40,799	
450	448,00	3,1	2170	1,06	MRD63	16800	79,8	70	17	40,766	
560	560,00	2,5	2712	0,85	MRD63	18000	79,8	70	17	40,748	
1.1	2,5	2,53	548	18,4	2,34	MRD12	1569	16,8	4,8	33	1,4856
	3,15	3,08	451	22,4	2,05	MRD12	1650	16,8	4,8	33	1,3036
	4,0	4,01	347	29	1,71	MRD12	1761	16,8	4,8	33	1,1395
	5,0	5,07	274	37	1,43	MRD12	1855	16,8	4,8	33	1,0436
	5,01	5,01	277	36	2,89	MRD22	2160	19,6	7,6	33	2,1816

RD Gearboxes

MRD

Geared Motor Selection

1400 rpm

P ₁ [kW]	i _n	i _r	N ₂ [rpm]	M ₂ [Nm]	FS	Size	F _{r2} [N]	MRD [kg]	FRD [kg]	J _m × 10 ⁻⁴	J ₁ × 10 ⁻⁴
1.1	6,3	6,69	208	49	1,79	MRD12	1870	16,9	4,9	33	1,2060
	8,0	8,13	171	59	1,49	MRD12	1800	16,9	4,9	33	1,1144
		8,27	168	60	2,95	MRD22	2510	19,8	7,8	33	2,4162
	10,0	10,58	131	77	1,16	MRD12	1660	16,9	4,9	33	1,0278
		10,33	135	75	2,39	MRD22	2650	19,8	7,8	33	2,1765
	12,5	13,38	104	97	0,93	MRD12	1420	16,9	4,9	33	0,9738
		13,23	105	96	1,89	MRD22	2790	19,8	7,8	33	1,9928
	16,0	16,30	85	118	0,77	MRD12	1030	17,0	5,0	33	0,9414
		16,29	85	118	1,55	MRD22	2900	19,9	7,9	33	1,8826
		16,45	84	119	3,24	MRD32	6290	25,2	13,2	33	3,2491
20,0	20,67	67	150	1,23	MRD22	2850	19,9	7,9	33	1,7924	
		19,36	72	141	2,77	MRD32	6560	25,2	13,2	33	2,9048
	25,0	26,73	52	194	0,97	MRD22	2380	19,9	7,9	33	1,7234
		25,26	55	183	2,15	MRD32	7020	25,3	13,3	33	2,3847
		24,48	57	178	3,65	MRD42	8820	31,9	19,9	33	8,3681
31,5	31,48	44	228	0,83	MRD22	1820	19,9	7,9	33	1,6937	
		33,21	42	241	1,66	MRD32	6900	25,3	13,3	33	2,2448
		29,64	47	215	3,00	MRD42	9290	31,9	19,9	33	8,0069
40	38,57	36	280	1,01	MRD32	6470	25,6	13,6	33	2,3551	
		41,54	33	301	1,50	MRD42	9860	32,3	20,3	33	7,9357
		38,06	37	276	1,52	MRD33	3800	26,5	14,5	33	2,3981
		41,88	37,1	272	2,57	MRD43	9700	33,4	21,4	33	7,8832
		40,48	34,8	292	2,92	MRD52	10500	61	49	33	10,858
50	50,73	27	368	0,77	MRD32	5800	25,6	13,6	33	2,2276	
		50,30	28	365	1,23	MRD42	9310	32,3	20,3	33	7,7368
		48,77	28	354	1,19	MRD33	5400	26,5	14,5	33	4,8359
		51,08	29,0	348	1,80	MRD43	9500	33,4	21,4	33	10,261
		53,33	26,3	384	2,21	MRD52	11200	61	49	33	10,579
63	62,96	22	457	0,98	MRD42	8200	32,4	20,4	33	7,5664	
		64,84	21	471	0,90	MRD33	4000	26,6	14,6	33	5,2297
		63,75	21,8	463	1,51	MRD43	8700	33,5	21,5	33	10,644
		66,67	21,0	480	1,77	MRD52	12000	61	49	33	10,340
		59,88	23,4	422	3,05	MRD53	7800	64	52	33	14,391
80	76,31	18	554	0,76	MRD33	3000	26,6	14,6	33	5,0309	
		82,25	18,5	545	1,28	MRD43	6700	33,6	21,6	33	10,426
		77,26	18,1	545	2,39	MRD53	7900	64	52	33	14,087
100	102,50	14,2	710	0,98	MRD43	5500	33,8	21,8	33	10,081	
		96,28	14,5	679	1,91	MRD53	7900	64	52	33	13,603
		104,08	13,5	734	3,13	MRD63	11900	82	70	33	34,980
125	129,80	10,8	916	1,42	MRD53	8100	64	52	33	13,576	
		125,87	11,1	888	2,59	MRD63	12000	82	70	33	34,910
	160	157,14	8,9	1108	1,17	MRD53	8200	64	52	33	16,600
		157,33	8,9	1110	2,07	MRD63	12300	82	70	33	42,685
	200	195,82	7,1	1381	0,94	MRD53	8400	64	52	33	16,328
		201,57	6,9	1422	1,62	MRD63	12600	82	70	33	41,987
	250	264,00	5,3	1862	0,70	MRD53	8700	64	52	33	15,854
		265,50	5,3	1873	1,23	MRD63	13000	82	70	33	40,766
	315	332,00	4,2	2342	0,98	MRD63	13500	82	70	33	40,777
355	373,33	3,8	2633	0,87	MRD63	15700	82	70	33	40,799	
450	448,00	3,1	3160	0,73	MRD63	16800	82	70	33	40,766	

MRD

Gearboxes RD

1400 rpm

Geared Motor Selection

P ₁ [kW]	i _n	i _r	N ₂ [rpm]	M ₂ [Nm]	FS	Size	F _{r2} [N]	MRD [kg]	FRD [kg]	J _m × 10 ⁻⁴	J ₁ × 10 ⁻⁴
1.5	2,5	2,55	550	25	3,42	MRD22	1950	21,1	7,6	40	3,4569
	3,15	3,13	447	31	2,99	MRD22	1840	21,1	7,6	40	2,8995
	4,0	3,92	357	38	2,56	MRD22	1950	21,1	7,6	40	2,4858
	5,0	5,01	279	49	2,14	MRD22	2060	21,1	7,6	40	2,1816
	6,3	6,72	208	66	2,65	MRD22	2280	21,1	7,6	40	2,7248
	8,0	8,27	169	81	2,18	MRD22	2380	21,3	7,8	40	2,4162
	10,0	10,33	135	102	1,76	MRD22	2490	21,3	7,8	40	2,1765
	12,5	13,23	106	130	1,39	MRD22	2580	21,3	7,8	40	1,9928
		12,38	113	122	3,13	MRD32	5500	26,6	13,1	40	3,1944
	16,0	16,29	86	160	1,14	MRD22	2650	21,4	7,9	40	1,8826
		16,45	85	162	2,39	MRD32	6080	26,7	13,2	40	3,2491
	20,0	20,67	68	203	0,91	MRD22	2230	21,4	7,9	40	1,7924
		19,36	72	190	2,05	MRD32	6310	26,7	13,2	40	2,9048
		19,64	71	193	3,36	MRD42	8050	33,3	19,8	40	8,3681
	25,0	26,73	52	263	0,71	MRD22	2100	21,4	7,9	40	1,7234
		25,26	55	248	1,59	MRD32	6705	26,8	13,3	40	2,3847
		24,48	57	241	2,70	MRD42	8510	33,4	19,9	40	8,3681
	31,5	33,21	42	326	1,23	MRD32	5700	26,8	13,3	40	2,2448
		29,64	47	291	2,23	MRD42	8920	33,4	19,9	40	8,0069
	40	38,57	36	379	0,75	MRD32	5000	27,1	13,6	40	2,3551
		41,54	34	408	1,10	MRD42	8830	33,8	20,3	40	7,9357
		38,06	37	374	1,12	MRD33	3000	28,0	14,5	40	2,3981
		41,88	37,4	368	1,90	MRD43	9200	34,9	21,4	40	7,8832
		40,48	34,6	398	2,14	MRD52	10500	62,5	49,0	40	10,858
		39,33	35,6	378	3,36	MRD53	7600	65,5	52,0	40	10,526
	50	50,30	28	494	0,91	MRD42	7850	33,8	20,3	40	7,7368
		48,77	29	479	0,88	MRD33	4500	28,0	14,5	40	4,8359
		51,08	29,2	471	1,49	MRD43	8100	34,9	21,4	40	10,261
		53,33	26,3	524	1,62	MRD52	11200	62,5	49,0	40	10,579
		47,98	29,2	462	2,77	MRD53	7800	65,5	52,0	40	13,854
		49,80	28,1	489	3,27	MRD62	16800	75,5	62,0	40	27,203
	63	63,75	22,0	626	1,11	MRD43	6000	35,0	21,5	40	10,644
		66,67	21,0	655	1,30	MRD52	12000	62,5	49,0	40	10,340
		59,88	23,4	576	2,24	MRD53	7800	65,5	52,0	40	14,391
		56,00	25,0	550	2,91	MRD62	18000	75,5	62,0	40	25,590
	80	82,25	18,7	737	0,95	MRD43	6100	35,1	21,6	40	10,426
	77,26	18,1	743	1,75	MRD53	7900	65,5	52,0	40	14,087	
	81,29	17,2	782	2,94	MRD63	11900	83,5	70,0	40	36,223	
100	96,28	14,5	926	1,40	MRD53	7900	65,5	52,0	40	13,603	
	104,08	13,5	1001	2,30	MRD63	11900	83,5	70,0	40	34,980	
125	129,80	10,8	1248	1,04	MRD53	8100	65,5	52,0	40	13,576	
	125,87	11,1	1211	1,90	MRD63	12000	83,5	70,0	40	34,910	
160	157,14	8,9	1511	0,86	MRD53	8200	65,5	52,0	40	16,600	
	157,33	8,9	1513	1,52	MRD63	12300	83,5	70,0	40	42,685	
200	201,57	6,9	1939	1,18	MRD63	12600	83,5	70,0	40	41,987	
250	265,50	5,3	2554	0,90	MRD63	13000	83,5	70,0	40	40,766	
315	332,00	4,2	3193	0,72	MRD63	13500	83,5	70,0	40	40,774	
1.8	2,5	2,55	550	31	2,79	MRD22	1710	23,1	7,6	50	3,4569
	3,15	3,13	447	38	2,44	MRD22	1795	23,1	7,6	50	2,8995
	4,0	3,92	357	47	2,09	MRD22	1885	23,1	7,6	50	2,4858

RD Gearboxes

MRD

Geared Motor Selection

1400 rpm

P ₁ [kW]	i _n	i _r	N ₂ [rpm]	M ₂ [Nm]	FS	Size	F _{r2} [N]	MRD [kg]	FRD [kg]	J _m × 10 ⁻⁴	J ₁ × 10 ⁻⁴
1.8	5,0	5,01	279	60	1,74	MRD22	1978	23,1	7,6	50	2,1816
	6,3	6,72	208	81	2,16	MRD22	2194	23,1	7,6	50	2,7248
	8,0	8,27	169	100	1,78	MRD22	2270	23,3	7,8	50	2,4162
	10,0	10,33	135	125	1,44	MRD22	2346	23,3	7,8	50	2,1765
		9,66	145	116	3,23	MRD32	5000	28,6	13,1	50	3,7274
	12,5	13,23	106	159	1,14	MRD22	2402	23,3	7,8	50	1,9928
		12,38	113	149	2,56	MRD32	5490	28,6	13,1	50	3,1944
	16,0	16,29	86	196	0,93	MRD22	2300	23,4	7,9	50	1,8826
		16,45	85	198	1,95	MRD32	5890	28,7	13,2	50	3,2491
		15,22	92	183	3,12	MRD42	7000	35,2	19,7	50	8,9476
	20,0	20,67	68	249	0,74	MRD22	2100	23,4	7,9	50	1,7924
		19,36	72	233	1,67	MRD32	6010	28,7	13,2	50	2,9048
		19,64	71	237	2,45	MRD42	7850	35,3	19,8	50	8,3681
	25,0	25,26	55	304	1,30	MRD32	6050	28,8	13,3	50	2,3847
		24,48	57	295	2,20	MRD42	8270	35,4	19,9	50	8,0069
	31,5	33,21	42	400	1,00	MRD32	3950	28,8	13,3	50	2,2448
		29,64	47	357	1,82	MRD42	8620	35,4	19,9	50	7,7854
		31,43	44,5	370	3,35	MRD52	9100	64,5	49,0	50	10,647
	40	41,54	34	501	0,90	MRD42	7100	35,8	20,3	50	7,7368
		38,06	37	459	0,91	MRD33	4000	30,0	14,5	50	2,3981
		41,88	37,4	451	1,55	MRD43	8000	36,9	21,4	50	7,8832
		40,48	34,6	477	1,78	MRD52	10500	64,5	49,0	50	10,858
		39,33	35,6	454	2,80	MRD53	7600	67,5	52,0	50	10,523
	50	40,50	34,6	477	3,35	MRD62	15700	77,5	62,0	50	27,919
		48,77	29	588	0,72	MRD33	3500	30,0	14,5	50	4,8359
		47,95	29,2	578	1,21	MRD43	6100	36,9	21,4	50	10,2607
		53,33	26,3	629	1,35	MRD52	11200	64,5	49,0	50	10,579
		47,98	29,2	554	2,31	MRD53	7800	67,5	52,0	50	13,854
	63	49,80	28,1	587	2,73	MRD62	16800	77,5	62,0	50	27,203
		63,75	22,0	768	0,91	MRD43	5000	37,0	21,5	50	10,6441
		66,67	21,0	786	1,08	MRD52	12000	64,5	49,0	50	10,340
		59,88	23,4	691	1,87	MRD53	7800	67,5	52,0	50	14,391
56,00		25,0	660	2,42	MRD62	18000	77,5	62,0	50	26,590	
80	61,88	22,6	714	3,08	MRD63	11700	85,5	70,0	50	37,004	
	82,25	18,7	904	0,78	MRD43	4000	37,1	21,6	50	10,4264	
	77,26	18,1	892	1,46	MRD53	7900	67,5	52,0	50	14,087	
	81,29	17,2	938	2,45	MRD63	11900	85,5	70,0	50	36,223	
	96,28	14,5	1111	1,17	MRD53	7900	67,5	52,0	50	13,603	
125	104,08	13,5	1201	1,91	MRD63	11900	85,5	70,0	50	34,980	
	129,80	10,8	1498	0,87	MRD53	8100	67,5	52,0	50	13,576	
	125,87	11,1	1453	1,58	MRD63	12000	85,5	70,0	50	34,910	
160	157,14	8,9	1814	0,72	MRD53	8200	67,5	52,0	50	16,600	
	157,33	8,9	1816	1,27	MRD63	12300	85,5	70,0	50	42,685	
200	201,57	6,9	2327	0,99	MRD63	12600	85,5	70,0	50	41,987	
250	265,50	5,3	3064	0,75	MRD63	13000	85,5	70,0	50	40,766	
2.2	2,5	2,55	558	36	2,36	MRD22	1670	26,6	7,6	75	3,8842
	3,15	3,13	453	45	2,07	MRD22	1740	26,6	7,6	75	3,3268
	4,0	3,92	363	56	1,77	MRD22	1820	26,6	7,6	75	2,9131
	5,0	5,01	283	71	1,48	MRD22	1890	26,6	7,6	75	2,6089
	5,33	266	76	3,10	MRD32	4250	32,6	13,6	75	4,2003	

MRD

Gearboxes RD

1400 rpm

Geared Motor Selection

P ₁ [kW]	i _n	i _r	N ₂ [rpm]	M ₂ [Nm]	FS	Size	F _{r2} [N]	MRD [kg]	FRD [kg]	J _m × 10 ⁻⁴	J ₁ × 10 ⁻⁴
2.2	6,3	6,72	211	95	1,83	MRD22	2100	26,6	7,6	75	3,1521
	8,0	8,27	172	117	1,51	MRD22	2160	26,8	7,8	75	2,8435
		7,72	184	110	3,39	MRD32	4800	32,8	13,8	75	4,8413
	10,0	10,33	137	147	1,22	MRD22	2200	26,8	7,8	75	2,6037
		9,66	147	137	2,74	MRD32	5050	32,9	13,9	75	4,1539
	12,5	13,23	107	188	0,96	MRD22	2220	26,8	7,8	75	2,4201
		12,38	115	176	2,17	MRD32	5360	32,9	13,9	75	3,6208
		12,20	116	173	3,58	MRD42	6800	39,5	20,5	75	9,4739
	16,0	16,29	87	231	0,79	MRD22	1650	26,9	7,9	75	2,3099
		16,45	86	234	1,65	MRD32	5710	33,0	14,0	75	3,6755
		15,22	93	216	3,00	MRD42	7180	39,6	20,6	75	8,7672
	20,0	19,36	73	275	1,42	MRD32	5890	33,0	14,0	75	3,3312
		19,64	72	279	2,32	MRD42	7620	39,7	20,7	75	8,1877
	25,0	25,26	56	359	1,10	MRD32	5000	33,1	14,1	75	2,8112
		24,48	58	348	1,86	MRD42	7990	39,8	20,8	75	7,8266
		25,99	54	372	3,31	MRD52	9000	68,0	49,0	75	10,962
	31,5	33,21	43	472	0,85	MRD32	4200	33,1	14,1	75	2,6712
		29,64	48	421	1,54	MRD42	8290	39,8	20,8	75	7,6050
		31,43	45	450	2,76	MRD52	9100	68,0	49,0	75	10,547
	40	41,88	38	532	1,31	MRD43	6800	41,2	22,2	75	7,6977
		40,48	35	579	1,47	MRD52	10500	68,0	49,0	75	10,858
		39,33	36	551	2,31	MRD53	7600	71,0	52,0	75	10,526
		40,50	35	579	2,76	MRD62	15700	81,0	62,0	75	27,919
	50	51,08	29,6	681	1,02	MRD43	5500	41,2	22,2	75	10,0753
		53,33	26	763	1,11	MRD52	11200	68	49	75	10,579
		47,98	29	672	1,90	MRD53	7800	71	52	75	13,854
		49,80	28	712	2,25	MRD62	16800	81	62	75	27,203
		48,95	29	686	3,21	MRD63	11700	89	70	75	35,625
		63	66,67	21	954	0,89	MRD52	12000	68	49	75
	63	59,88	24	839	1,54	MRD53	7800	71	52	75	14,391
		56,00	25	801	2,00	MRD62	18000	81	62	75	26,590
		61,88	23	867	2,54	MRD63	11700	89	70	75	37,004
80		77,26	18	1082	1,20	MRD53	7900	71	52	75	14,087
100	81,29	17	1139	2,02	MRD63	11900	89	70	75	36,223	
	96,28	15	1349	0,96	MRD53	7900	71	52	75	13,603	
	104,08	14	1458	1,58	MRD63	11900	89	70	75	34,980	
125	129,80	11	1818	0,72	MRD53	8100	71	52	75	13,576	
	125,87	11	1763	1,30	MRD63	12000	89	70	75	34,910	
160	157,33	9,0	2204	1,04	MRD63	12300	89	70	75	42,685	
200	201,57	7,0	2823	0,81	MRD63	12600	89	70	75	41,987	
3.0	2,5	2,55	562	49	1,75	MRD22	1570	28,6	7,6	85	3,8842
	3,15	3,13	456	60	1,53	MRD22	1620	28,6	7,6	85	3,3268
		3,32	430	64	3,21	MRD32	3630	34,5	13,5	85	6,3316
	4,0	3,92	365	75	1,31	MRD22	1660	28,6	7,6	85	2,9131
		4,16	344	80	2,75	MRD32	3850	34,6	13,6	85	5,1053
	5,0	5,01	285	96	1,09	MRD22	1700	28,6	7,6	85	2,6089
		5,33	268	103	2,29	MRD32	4080	34,6	13,6	85	4,2003
	6,3	6,72	213	129	1,35	MRD22	1890	28,6	7,6	85	3,1521
		6,26	228	120	3,06	MRD32	4360	32,1	11,1	85	5,7232
	8,0	8,27	173	159	1,11	MRD22	1900	28,8	7,8	85	2,8435

RD Gearboxes

MRD

Geared Motor Selection

1400 rpm

P ₁ [kW]	i _n	i _r	N ₂ [rpm]	M ₂ [Nm]	FS	Size	F _{r2} [N]	MRD [kg]	FRD [kg]	J _m × 10 ⁻⁴	J ₁ × 10 ⁻⁴	
3.0	8.0	7,72	185	148	2,51	MRD32	4580	34,8	13,8	85	4,8413	
	10,0	10,33	138	199	0,90	MRD22	1880	28,8	7,8	85	2,6037	
		9,66	148	186	2,03	MRD32	4800	34,9	13,9	85	4,1539	
		10,00	143	192	2,91	MRD42	6200	41,4	20,4	85	10,3311	
	12,5	13,23	108	254	0,71	MRD22	1600	28,8	7,8	85	2,4201	
		12,38	116	238	1,60	MRD32	5040	34,9	13,9	85	3,6208	
		12,20	117	235	2,63	MRD42	6500	41,5	20,5	85	9,4739	
	16,0	16,45	87	317	1,22	MRD32	5300	35,0	14,0	85	3,6755	
		15,22	94	293	1,96	MRD42	6810	41,6	20,6	85	8,7672	
		19,36	74	373	1,05	MRD32	4500	35,0	14,0	85	3,3312	
	20,0	19,64	73	378	1,71	MRD42	7150	41,7	20,7	85	8,1877	
		20,30	70	393	3,10	MRD52	8700	70,0	49,0	85	11,463	
		25,0	25,26	57	486	0,81	MRD32	4000	35,1	14,1	85	2,8112
		24,48	58	471	1,38	MRD42	7400	41,8	20,8	85	7,8266	
		25,99	55	503	2,44	MRD52	9000	70,0	49,0	85	10,962	
	31,5	29,64	48	570	1,14	MRD42	6110	41,8	20,8	85	7,6050	
		31,43	45	609	2,04	MRD52	9100	70,0	49,0	85	10,647	
		33,20	43	643	3,45	MRD62	13700	83,0	62,0	85	27,378	
		40	41,88	38,2	720	0,97	MRD43	5800	43,2	22,2	85	7,6977
	40	40,48	35	784	1,08	MRD52	10500	70,0	49,0	85	10,858	
		39,33	36	746	1,70	MRD53	7600	73,0	52,0	85	10,526	
		40,50	35	784	2,04	MRD62	15700	83,0	62,0	85	27,920	
		39,71	36	753	2,92	MRD63	11400	91,0	70,0	85	27,066	
		50	53,33	27	1033	0,82	MRD52	11200	70,0	49,0	85	10,579
		47,98	30	910	1,41	MRD53	7800	73,0	52,0	85	13,854	
		49,80	29	965	1,66	MRD62	16800	83,0	62,0	85	27,203	
		48,95	29	928	2,37	MRD63	11700	91,0	70,0	85	35,625	
		63	59,88	24	1136	1,14	MRD53	7800	73,0	52,0	85	14,391
		56,00	25	1085	1,48	MRD62	18000	83,0	62,0	85	26,590	
	80	61,88	23	1174	1,87	MRD63	11700	91,0	70,0	85	37,004	
77,26		18	1465	0,89	MRD53	7900	73,0	52,0	85	14,087		
81,29		18	1542	1,49	MRD63	11900	91,0	70,0	85	36,223		
100		96,28	15	1826	0,71	MRD53	7900	73,0	52,0	85	13,603	
104,08		14	1974	1,17	MRD63	11900	91,0	70,0	85	34,980		
125		125,87	11	2387	0,96	MRD63	12000	91,0	70,0	85	34,910	
160	157,33	9,0	2984	0,77	MRD63	12300	91,0	70,0	85	42,685		
4.0	2,5	2,70	528	69	2,74	MRD32	3330	36,5	13,5	130	7,9870	
	3,15	3,32	429	86	2,40	MRD32	3500	42,5	13,5	130	6,3316	
	4,0	4,16	343	107	2,05	MRD32	3690	42,6	13,6	130	5,1053	
		3,96	360	102	3,72	MRD42	4000	48,8	19,8	130	12,3170	
	5,0	5,33	267	137	1,71	MRD32	3880	42,6	13,6	130	4,2003	
		4,83	295	124	3,06	MRD42	4850	48,8	19,8	130	10,8083	
	6,3	6,26	228	161	2,29	MRD32	4160	40,1	11,1	130	5,7232	
		6,29	227	162	3,50	MRD42	5340	49,3	20,3	130	13,6364	
	8,0	7,72	185	199	1,87	MRD32	4330	42,8	13,8	130	4,8413	
		7,86	181	202	3,06	MRD42	5620	49,3	20,3	130	11,7587	
	10,0	9,66	148	249	1,51	MRD32	4500	42,9	13,9	130	4,1539	
		10,00	143	257	2,41	MRD42	5920	49,4	20,4	130	10,3311	
	12,5	12,38	115	319	1,20	MRD32	4650	42,9	13,9	130	3,6208	
		12,20	117	314	1,97	MRD42	6150	49,5	20,5	130	9,4739	

MRD

Gearboxes RD

1400 rpm

Geared Motor Selection

P ₁ [kW]	i _n	i _r	N ₂ [rpm]	M ₂ [Nm]	FS	Size	F _{r2} [N]	MRD [kg]	FRD [kg]	J _m × 10 ⁻⁴	J ₁ × 10 ⁻⁴
4.0	16,0	16,45	87	424	0,91	MRD32	2900	43,0	14,0	130	3,6755
		15,22	94	392	1,65	MRD42	6380	49,6	20,6	130	8,7672
		15,45	92	398	3,02	MRD52	8500	72,0	49,0	130	12,274
	20,0	19,36	74	498	0,78	MRD32	2500	43,0	14,0	130	3,3312
		19,64	73	506	1,28	MRD42	6590	49,7	20,7	130	8,1877
		20,30	70	522	2,34	MRD52	8700	72,0	49,0	130	11,463
	25,0	24,48	58	630	1,03	MRD42	4290	49,8	20,8	130	7,8266
		25,99	55	669	1,84	MRD52	9000	72,0	49,0	130	10,962
		24,62	58	633	3,32	MRD62	13500	85,0	62,0	130	28,188
	31,5	29,64	48	763	0,85	MRD42	4000	49,8	20,8	130	7,6050
		31,43	45	809	1,53	MRD52	9100	72,0	49,0	130	10,647
		33,20	43	854	2,60	MRD62	13700	85,0	62,0	130	27,378
	40	40,48	35	1042	0,82	MRD52	10500	72,0	49,0	130	10,858
		39,33	36	991	1,28	MRD53	7600	75,0	52,0	130	10,526
		40,50	35	1042	1,54	MRD62	15700	85,0	62,0	130	27,919
	50	39,71	36	1001	2,20	MRD63	11400	93,0	70,0	130	27,066
		47,98	30	1209	1,06	MRD53	7800	75,0	52,0	130	13,854
		49,80	29	1282	1,25	MRD62	16800	85,0	62,0	130	27,203
	63	48,95	29	1233	1,78	MRD63	11700	93,0	70,0	130	35,625
		59,88	24	1509	0,85	MRD53	7800	75,0	52,0	130	14,391
56,00		25	1441	1,11	MRD62	18000	85,0	62,0	130	26,590	
80	61,88	23	1559	1,41	MRD63	11700	93	70,0	130	37,004	
	81,29	18	2048	1,12	MRD63	11900	93,0	70,0	130	36,223	
	100	14	2623	0,88	MRD63	11900	93,0	70,0	130	34,980	
125	11	3172	0,73	MRD63	12000	93,0	70,0	130	34,910		
5.5	2,5	2,49	579	87	3,50	MRD42	3950	58,0	23,0	240	17,5055
	3,15	3,11	463	109	2,94	MRD42	4167	58,0	23,0	240	13,8183
	4,0	3,96	364	139	2,73	MRD42	4400	58,1	23,1	240	11,1597
	5,0	4,83	298	169	2,36	MRD42	4580	58,1	23,1	240	9,6510
	6,3	6,29	229	220	2,81	MRD42	5050	58,6	23,6	240	12,4792
	8,0	7,86	183	275	2,25	MRD42	5270	58,6	23,6	240	10,6015
	10,0	10,00	144	350	1,77	MRD42	5480	58,7	23,7	240	9,1738
		9,92	145	347	3,40	MRD52	5500	84,0	49,0	240	14,463
	12,5	12,20	118	427	1,45	MRD42	5610	58,8	23,8	240	8,3166
		12,22	118	428	2,78	MRD52	6900	84,0	49,0	240	13,264
	16,0	15,22	95	533	1,22	MRD42	5710	58,9	23,9	240	7,6100
		15,45	93	541	2,22	MRD52	8500	84,0	49,0	240	12,274
	20,0	19,64	73	688	0,95	MRD42	5260	59,0	24,0	240	7,0305
		20,30	71	711	1,72	MRD52	8700	84,0	49,0	240	11,463
		20,67	70	724	2,90	MRD62	13000	97,00	62,00	240	29,476
	25,0	25,99	55	910	1,35	MRD52	9000	84,0	49,0	240	10,962
		24,62	59	862	2,44	MRD62	13500	97,0	62,0	240	28,188
	31,5	31,43	46	1101	1,13	MRD52	9100	84,0	49,0	240	10,647
		33,20	43	1163	1,91	MRD62	13700	97,0	62,0	240	27,378
	40	39,33	37	1349	0,94	MRD53	7600	87,0	52,0	240	10,526
40,50		36	1418	1,13	MRD62	15700	97,0	62,0	240	27,919	
39,71		36	1361	1,62	MRD63	11400	105	70,0	240	27,066	
50	47,98	30	1645	0,78	MRD53	7800	87,0	52,0	240	13,854	
	49,80	29	1744	0,92	MRD62	16800	97,0	62,0	240	27,203	
	48,95	29	1678	1,31	MRD63	11700	105	70,0	240	35,625	

RD Gearboxes

MRD

Geared Motor Selection

1400 rpm

P ₁ [kW]	i _n	i _r	N ₂ [rpm]	M ₂ [Nm]	FS	Size	F _{r2} [N]	MRD [kg]	FRD [kg]	J _m × 10 ⁻⁴	J ₁ × 10 ⁻⁴
5.5	63	56.00	26	1961	0.82	MRD62	18000	97.0	62.0	240	26.590
		61.88	23	2122	1.04	MRD63	11700	105	70.0	240	37.004
	80	81.29	18	2787	0.83	MRD63	11900	105	70.0	240	36.223
7.5	2,5	2,49	583	118	2,50	MRD42	3760	75,0	23,0	330	17,5055
		3,11	466	148	2,17	MRD42	3940	75,0	23,0	330	13,8183
	4,0	3,96	366	188	2,02	MRD42	4110	75,1	23,1	330	11,1597
		4,83	300	229	1,74	MRD42	4230	75,1	23,1	330	9,6510
	6,3	6,29	231	298	2,10	MRD42	4690	75,6	23,6	330	12,4792
		7,86	185	373	1,66	MRD42	4820	75,6	23,6	330	10,6015
	8,0	8,19	176	391	2,99	MRD52	5200	101	49,0	330	16,463
		10,00	145	474	1,30	MRD42	4900	75,7	23,7	330	9,1738
	12,5	9,92	145	473	2,49	MRD52	5500	101	49,0	330	14,463
		12,20	119	579	1,10	MRD42	4590	75,8	23,8	330	8,3166
	16,0	12,22	118	584	2,04	MRD52	6900	101	49,0	330	13,264
		12,44	116	594	3,53	MRD62	10300	114	62,0	330	34,106
	20,0	15,22	95	722	0,90	MRD42	5100	75,9	23,9	330	7,6100
		15,45	93	738	1,63	MRD52	8500	101	49,0	330	12,274
	25,0	15,73	92	751	2,80	MRD62	12800	114	62,0	330	31,562
		20,30	71	969	1,26	MRD52	8700	101	49,0	330	11,463
	31,5	20,67	70	987	2,13	MRD62	13000	114	62,0	330	29,476
		25,99	55	1241	0,99	MRD52	9000	101	49,0	330	10,962
	40	24,62	59	1175	1,79	MRD62	13500	114	62,0	330	28,188
		31,43	46	1501	0,83	MRD52	9100	101	49,0	330	10,647
	50	33,20	43	1585	1,40	MRD62	13700	114	62,0	330	27,378
40,50		36	1934	0,83	MRD62	15700	114	62,0	330	27,919	
63	39,71	36	1857	1,18	MRD63	11400	122	70,0	330	27,066	
	48,95	29	2289	0,96	MRD63	11700	122	70,0	330	35,625	
9.2	61,88	23	2893	0,76	MRD63	11700	122	70,0	330	37,004	
	2,5	2,49	587	144	2,05	MRD42	3610	77,0	23,0	340	17,506
3,15	3,11	469	180	1,78	MRD42	3750	77,0	23,0	340	13,818	
	3,96	369	229	1,65	MRD42	3870	77,1	23,1	340	11,160	
4,0	3,93	369	228	3,28	MRD52	4000	103	49,0	340	17,244	
	4,83	302	279	1,43	MRD42	3940	77,1	23,1	340	9,6510	
5,0	4,84	300	282	3,02	MRD52	4500	103	49,0	340	15,131	
	6,29	232	363	1,70	MRD42	4380	77,6	23,6	340	12,479	
6,3	6,45	225	375	3,09	MRD52	4600	103	49,0	340	23,290	
	7,86	186	454	1,36	MRD42	4430	77,6	23,6	340	10,602	
8,0	8,19	177	476	2,46	MRD52	5200	103	49,0	340	16,463	
	10,00	146	578	1,07	MRD42	3700	77,7	23,7	340	9,1738	
12,5	9,92	146	577	2,05	MRD52	5500	103	49,0	340	14,463	
	10,10	144	587	3,58	MRD62	8300	116	62,0	340	37,192	
16,0	12,20	120	705	0,88	MRD42	3000	77,8	23,8	340	8,3166	
	12,22	119	711	1,67	MRD52	6900	103	49,0	340	13,264	
20,0	12,44	117	724	2,90	MRD62	10300	116	62,0	340	34,106	
	15,45	94	899	1,34	MRD52	8500	103	49,0	340	12,274	
25,0	15,73	92	915	2,29	MRD62	12800	116	62,0	340	31,562	
	20,30	71	1181	1,03	MRD52	8700	103	49,0	340	11,463	
31,5	20,67	70	1202	1,75	MRD62	13000	116	62,0	340	29,476	
	25,99	56	1512	0,81	MRD52	9000	103	49,0	340	10,962	
40	24,62	59	1432	1,47	MRD62	13500	116	62,0	340	28,188	

MRD

Gearboxes RD

1400 rpm

Geared Motor Selection

P ₁ [kW]	i _n	i _r	N ₂ [rpm]	M ₂ [Nm]	FS	Size	F _{r2} [N]	MRD [kg]	FRD [kg]	J _m × 10 ⁻⁴	J ₁ × 10 ⁻⁴
9.2	31.5	33.20	44	1931	1.15	MRD62	13700	116	62.0	340	27.378
	40	39.71	37	2262	0.97	MRD63	11400	124	70.0	340	27.066
	50	48.95	30	2788	0.79	MRD63	11700	124	70.0	340	35.625
11	2.5	2.56	571	185	3.41	MRD52	3400	117	49	620	26.128
	3.15	3.24	451	234	2.95	MRD52	3700	117	49	620	20.966
	4.0	3.93	372	284	2.65	MRD52	4000	117	49	620	17.244
	5.0	4.84	302	350	2.43	MRD52	4500	117	49	620	15.131
	6.3	6.45	226	466	2.49	MRD52	4600	117	49	620	23.290
	8.0	8.19	178	591	1.98	MRD52	5200	117	49	620	16.463
		8.33	175	602	3.32	MRD62	7800	130	62	620	42.332
	10.0	9.92	147	716	1.65	MRD52	5500	117	49	620	14.463
		10.10	145	729	2.88	MRD62	8300	130	62	620	37.192
	12.5	12.22	120	883	1.35	MRD52	6900	117	49	620	13.264
		12.44	117	899	2.34	MRD62	10300	130	62	620	34.106
	16.0	15.45	95	1116	1.08	MRD52	8500	49	117	620	12.274
		15.73	93	1136	1.85	MRD62	12800	130	62	620	31.562
	20.0	20.30	72	1466	0.83	MRD52	8700	117	49	620	11.463
		20.67	70	1492	1.41	MRD62	13000	130	62	620	29.476
25.0	24.62	59	1778	1.18	MRD62	13500	130	62	620	28.188	
31.5	33.20	44	2397	0.93	MRD62	13700	130	62	620	27.378	
40	39.71	37	2808	0.78	MRD63	11400	138	70	620	27.066	
15	2.5	2.56	571	241	2.62	MRD52	3400	127	49	740	26.128
	3.15	3.24	451	305	2.26	MRD52	3700	127	49	740	20.966
	4.0	3.93	372	370	2.03	MRD52	4000	127	49	740	17.244
	5.0	4.84	302	456	1.86	MRD52	4500	127	49	740	15.131
	6.3	6.45	226	608	1.91	MRD52	4600	127	49	740	23.290
		6.57	222	619	3.23	MRD62	6900	140	62	740	59.890
	8.0	8.19	178	771	1.52	MRD52	5200	127	49	740	16.463
		8.33	175	785	2.55	MRD62	7800	140	62	740	42.332
	10	9.92	147	934	1.26	MRD52	5500	127	49	740	14.463
		10.10	145	951	2.21	MRD62	8300	140	62	740	37.192
	12.5	12.22	120	1151	1.03	MRD52	6900	127	49	740	13.264
		12.44	117	1172	1.79	MRD62	10300	140	62	740	34.106
	16.0	15.45	95	1455	0.82	MRD52	8500	127	49	740	12.274
		15.73	93	1482	1.42	MRD62	12800	140	62	740	31.562
	20.0	20.67	71	1947	1.08	MRD62	13000	140	62	740	29.476
25.0	24.62	59	2319	0.91	MRD62	13500	140	62	740	28.188	
31.5	33.20	44	3127	0.71	MRD62	13700	140	62	740	27.378	
18.5	2.5	2.56	575	295	2.14	MRD52	3400	159	49	900	26.128
	3.15	3.24	454	374	1.85	MRD52	3700	159	49	900	20.966
	4.0	3.93	374	453	1.66	MRD52	4000	159	49	900	17.244
		4.02	366	464	3.45	MRD62	6000	172	62	900	44.341
	5.0	4.84	304	558	1.52	MRD52	4500	159	49	900	15.131
		4.96	297	572	3.15	MRD62	6700	172	62	900	39.909
	6.3	6.45	228	745	1.56	MRD52	4600	159	49	900	23.290
		6.57	224	758	2.64	MRD62	6900	172	62	900	59.890
	8.0	8.19	180	944	1.24	MRD52	5200	159	49	900	16.463
		8.33	176	961	2.08	MRD62	7800	172	62	900	42.332
	10.0	9.92	148	1144	1.03	MRD52	5500	159	49	900	14.463
		10.10	146	1165	1.80	MRD62	8300	172	62	900	37.192

RD Gearboxes

MRD

Geared Motor Selection

1400 rpm

P ₁ [kW]	i _n	i _r	N ₂ [rpm]	M ₂ [Nm]	FS	Size	F _{r2} [N]	MRD [kg]	FRD [kg]	J _m × 10 ⁻⁴	J ₁ × 10 ⁻⁴	
18.5	12.5	12.22	120	1410	0.84	MRD52	6900	159	49	900	13.264	
		12.44	118	1436	1.46	MRD62	10300	172	62	900	34.106	
	16.0	15.73	93	1815	1.16	MRD62	12800	172	62	900	31.562	
	20.0	20.67	71	2385	0.88	MRD62	13000	172	62	900	29.476	
	25.0	24.62	60	2840	0.74	MRD62	13500	172	62	900	28.188	
22	2.5	2.56	575	351	1.80	MRD52	3400	168	49	1150	26.128	
		3.15	3.24	454	445	1.55	MRD52	3700	168	49	1150	20.966
			3.32	443	455	3.08	MRD62	5600	181	62	1150	53.914
	4.0	3.93	374	539	1.39	MRD52	4000	168	49	1150	17.244	
		4.02	366	551	2.90	MRD62	6000	181	62	1150	44.341	
	5.0	4.84	304	664	1.28	MRD52	4500	168	49	1150	15.131	
		4.96	297	680	2.65	MRD62	6700	181	62	1150	39.909	
	6.3	6.45	228	886	1.31	MRD52	4600	168	49	1150	23.290	
		6.57	224	902	2.22	MRD62	6900	181	62	1150	59.890	
	8.0	8.33	176	1143	1.75	MRD62	7800	181	62	1150	42.332	
	10.0	10.10	146	1385	1.52	MRD62	8300	181	62	1150	37.192	
	12.5	12.44	118	1707	1.23	MRD62	10300	181	62	1150	34.106	
	16.0	15.73	93	2159	0.97	MRD62	12800	181	62	1150	31.562	
20.0	20.67	71	2836	0.74	MRD62	13000	181	62	1150	29.476		

Gearboxes RD

Motor Quick-Reference Table

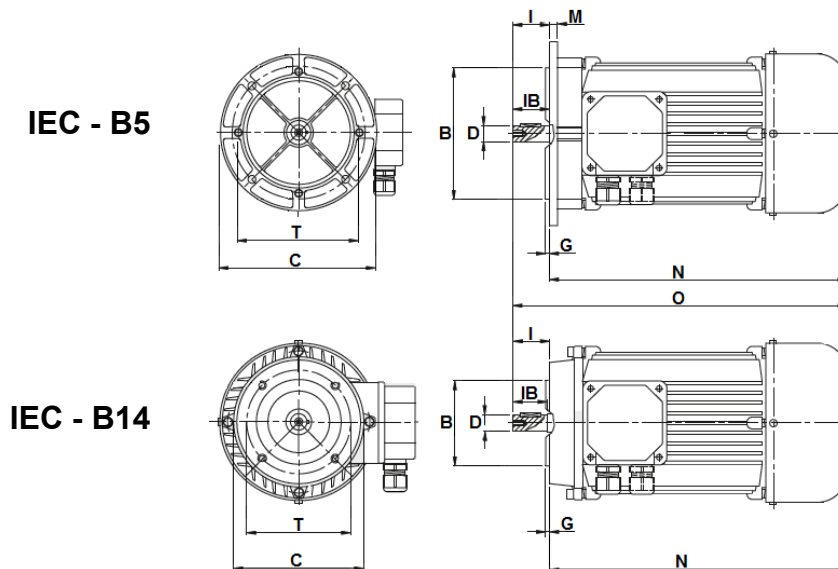

Frame	4 - poles			2 - poles			Flange C / T / B	Shaft D x l	G	IB	M	N	O
	kW	rpm	kg (B3)	kW	rpm	kg (B3)							
T56A	0.06	1410	2.5	0.09	2730	2.6	B5 - 120 / 100 / 80	9 x 20	2.5	20	8.5	168	188
T56B	0.09	1340	2.6	0.14	2750	3.2	B14 - 80 / 65 / 50					125	145
T63A	0.13	1340	3.7	0.18	2770	3.7	B5 - 140 / 115 / 95	11 x 23	2.5	23	10	190.5	213.5
T63B	0.18	1360	4.3	0.25	2820	4.3	B14 - 90 / 75 / 60					140	161
T71A	0.25	1410	5.8	0.37	2860	5.8	B5 - 160 / 130 / 110	14 x 30	3.0	30	10	218	248
T71B	0.37	1370	6.2	0.55	2860	6.2	B14 - 105 / 85 / 70					168	188
T80A	0.55	1430	8.5	0.75	2860	8.5	B5 - 200 / 165 / 130	19 x 40	3.0	40	11	248	282
T80B	0.75	1430	9.8	1.1	2850	9.8	B14 - 120 / 100 / 80						
T90S	1.1	1430	12.0	1.5	2880	12.0	B5 - 200 / 165 / 130	24 x 50	3.5	50	10	255	305
T90L	1.5	1430	13.5	2.2	2850	13.5	B14 - 140 / 115 / 95					280	330
T100A	2.2	1430	19.0	3	2910	18.5	B5 - 250 / 215 / 180	28 x 60	4.0	60	14	312	372
T100B	3	1430	21.0	4	2920	21.0	B14 - 160 / 130 / 110						
T112A	4	1440	29.0	5.5	2920	32.0	B5 - 250 / 215 / 180 B14 - 160 / 130 / 110	28 x 60	4.0	60	14	330	390
T132S	5.5	1460	43	7.5	2920	48	B5 - 300 / 265 / 230	38 x 80	4.0	80	20	380.5	460.5
T132M	7.5	1460	52	11	2940	54	B14 - 200 / 165 / 130					418.5	498.5
T132ML	9.2	1460	54	15	2940	58							
T160M	11	1470	90	---	---	---	B5 - 350 / 300 / 250	42 x 110	5.0	110	20	491	601
T160L	15	1480	100	18.5	2960	99	B14 - 250 / 215 / 180					535	645
T180M	18.5	1470	120	22	2940	110	B% - 350 / 300 / 250	48 x 110	5.0	110	20	610	720
T180L	22	1480	135	---	---	---							

Not binding dimensions and weights

Dimensions

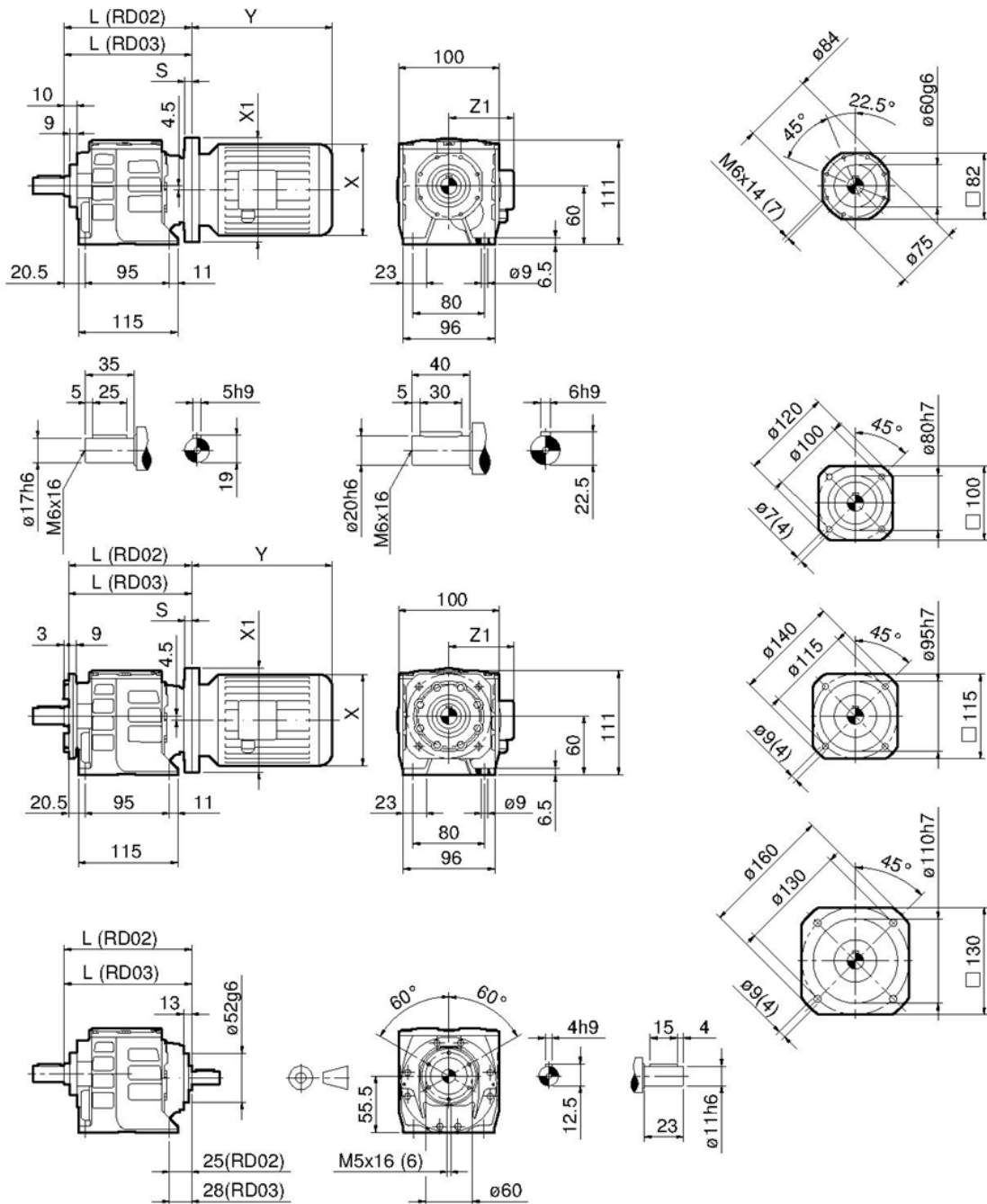

RD	02 / 03	02 / 03	02 / 03	02	---	---	---	---
IEC	56	63	71	80	---	---	---	---
X / Y / Z1	Dimensions: page 43				---	---	---	---
X1 (B5) / S	120/11	140/10	160/11.5	---	---	---	---	---
X1 (B14) / S	80/8	90/10	105/10	120/11	---	---	---	---
L (RD02)	140	140	140	140	---	---	---	---
L (RD03)	143	143	143	---	---	---	---	---

Not binding dimensions and weights

RD 12-13

Gearboxes RD

Dimensions

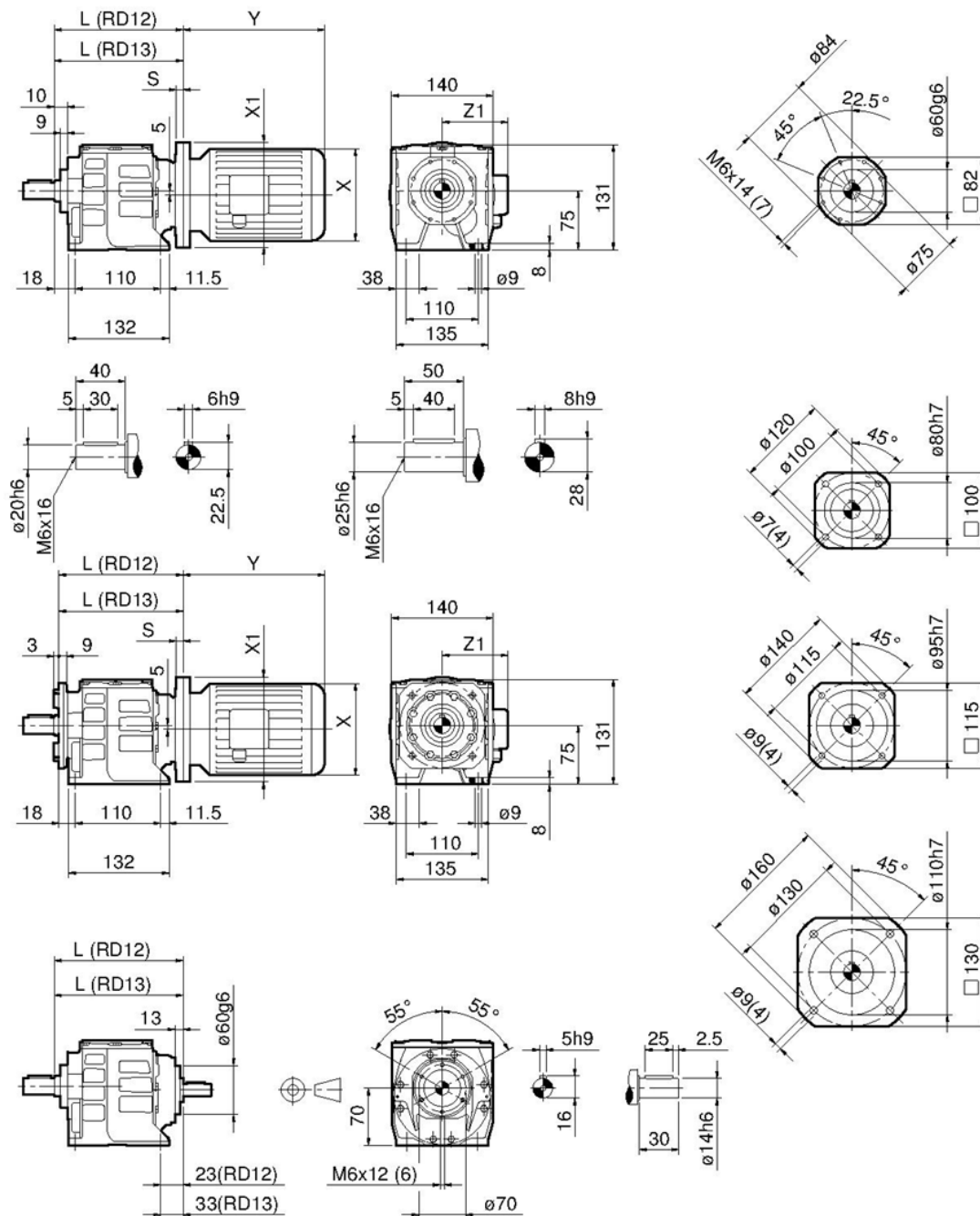

RD IEC	12 / 13 56	12 / 13 63	12 / 13 71	12 80	12 90 S	12 90 L	---	---
X / Y / Z1	Dimensions: page 43						---	---
X1 (B5) / S	120/11	140/10	160/11.5	200/11	200/11	200/11	---	---
X1 (B14) / S	---	90/8	105/10	120/11	140/10	140/10	---	---
L (RD12)	151	151	151 [B5] 155 [B14]	151	151	151	---	---
L (RD13)	161	161	161 [B5] 155 [B14]	161	161	161	---	---

Not binding dimensions and weights

Dimensions

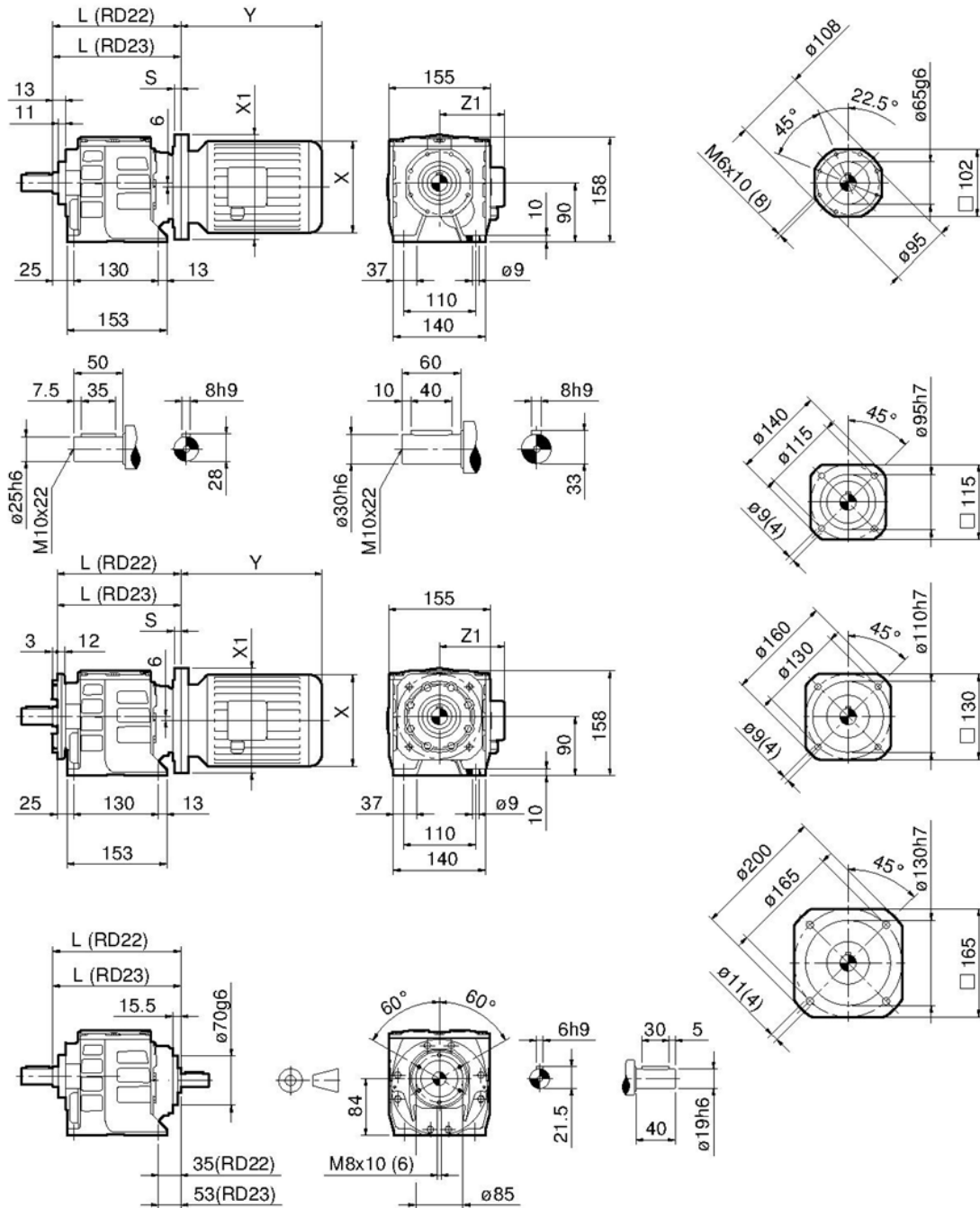

RD IEC	22 / 23 63	22 / 23 71	22 / 23 80	22 / 23 90 S	22 / 23 90 L	22 100	22 112	---
X / Y / Z1	Dimensions: page 43							---
X1 (B5) / S	140/10	160/11.5	200/11	200/11	200/11	250/13	250/13	---
X1 (B14) / S	---	105/10.5	120/10	140/10	140/10	160/11.5	160/11.5	---
L (RD22)	192	190	190[192- B14]	190[192- B14]	190[192- B14]	191[190- B14]	191[190- B14]	---
L (RD23)	211	209	209[211- B14]	209[211- B14]	209[211- B14]	---	---	---

Not binding dimensions and weights

RD 32-33

Gearboxes RD

Dimensions

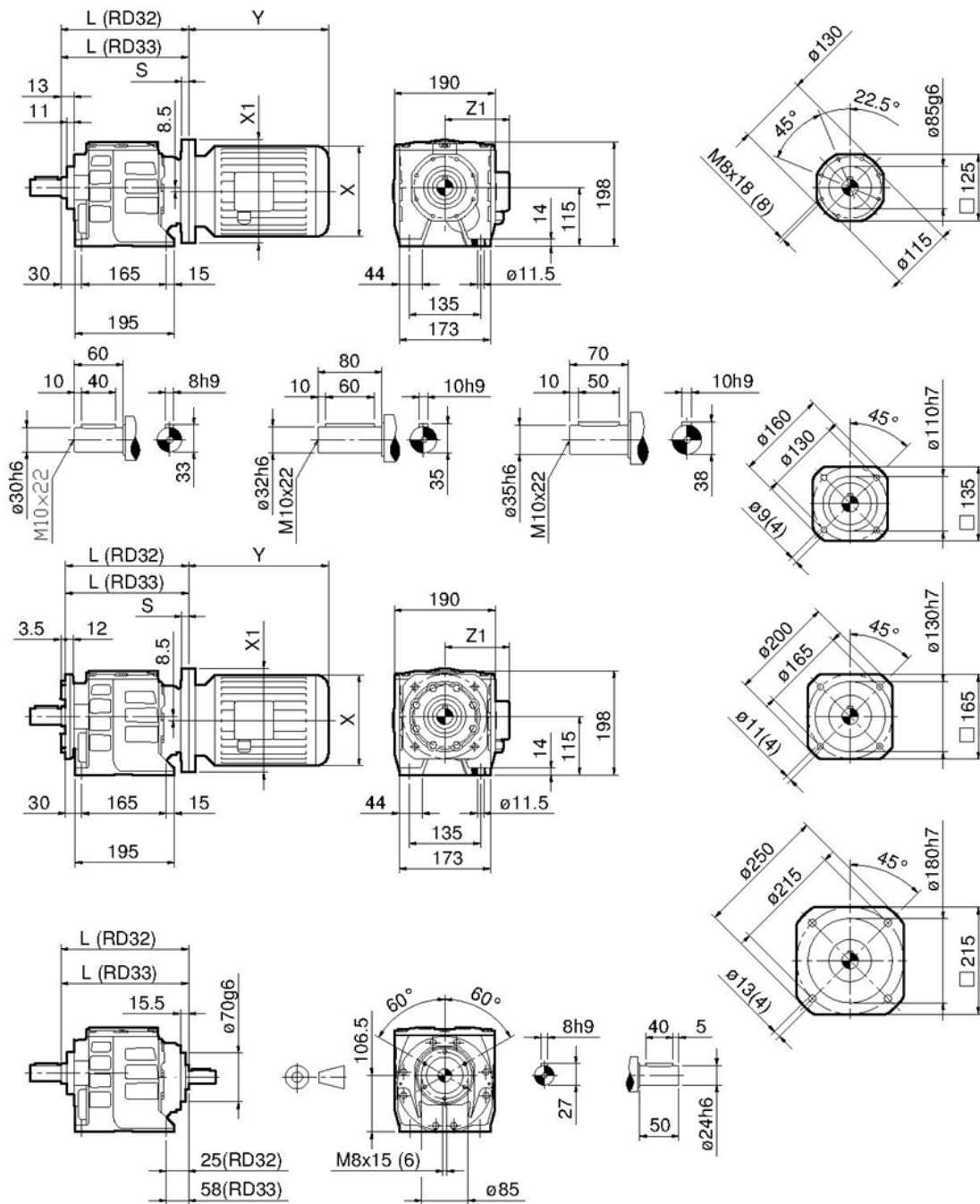

RD	32 / 33	32 / 33	32 / 33	32 / 33	32	32	---	---
IEC	71	80	90 S	90 L	100	112	---	---
X / Y / Z1	Dimensions: page 43							
X1 (B5) / S	160/11.5	200/11	200/11	200/11	250/13	250/13	---	---
X1 (B14) / S	105/10.5	120/10	140/10	140/10	160/11.5	160/11.5	---	---
L (RD32)	220	220 [B5] 222 [B14]	220 [B5] 222 [B14]	220 [B5] 222 [B14]	228 [B5] 221 [B14]	228 [B5] 221 [B14]	---	---
L (RD33)	253	253 [B5] 255 [B14]	253 [B5] 255 [B14]	253 [B5] 255 [B14]	---	---	---	---

Not binding dimensions and weights

RD Gearboxes

RD 42-43

Dimensions

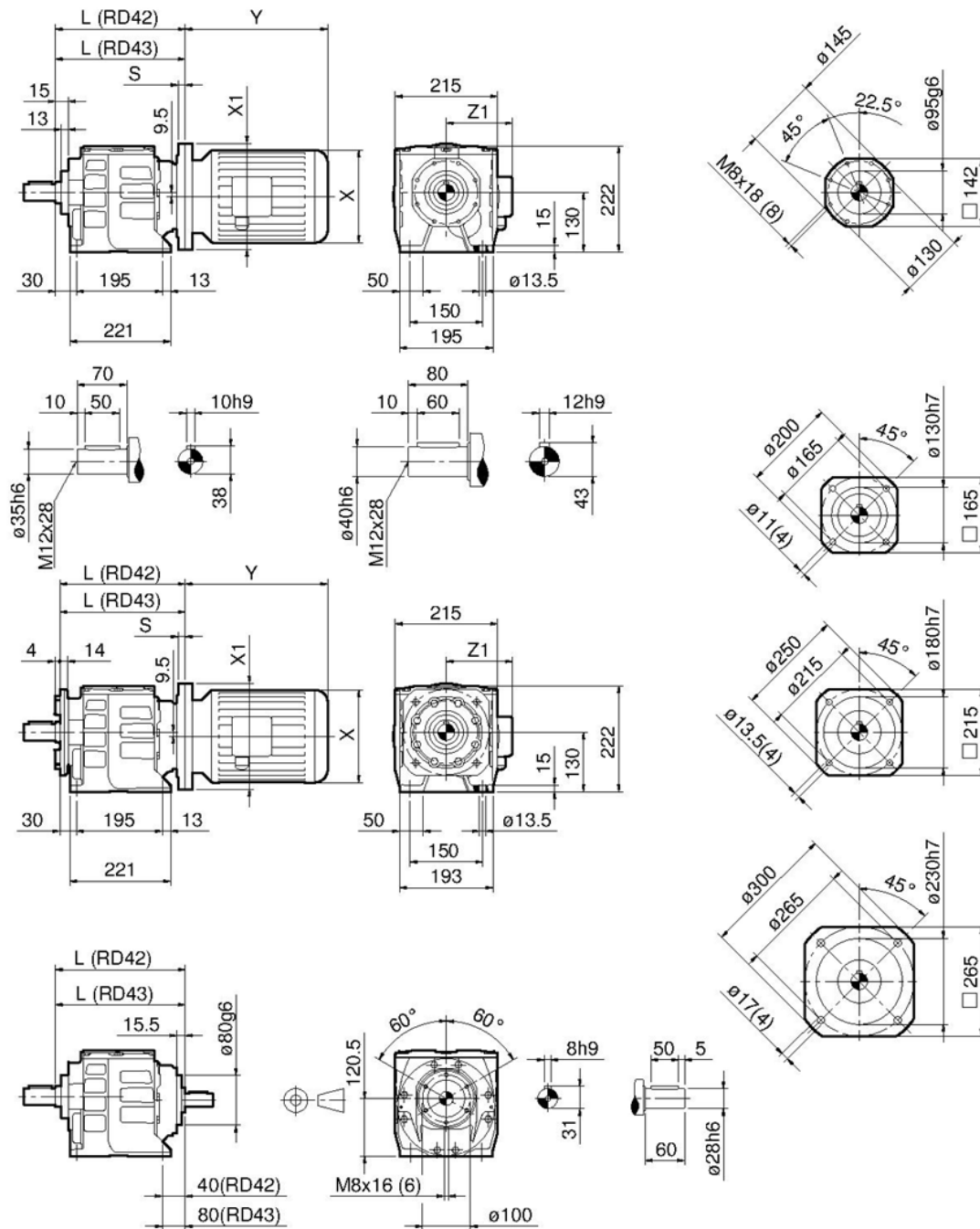

RD IEC	43	42 / 43 80	42 / 43 90 S	42 / 43 90 L	42 / 43 100	42 112	42 132 S	42 132 M
X / Y / Z1	Dimensions: page 43							
X1 (B5) / S	160/11.5	200/11.5	200/11.5	200/11.5	250/14	250/14	300/15	300/15
X1 (B14) / S	---	120/10	140/10	140/10	160/11.5	160/11.5	200/11.5	200/11.5
L (RD42)	---	265	265 [B5] 268 [B14]	265 [B5] 268 [B14]	266 [B5] 264 [B14]	266 [B5] 264 [B14]	268	268
L (RD43)	305	305	305 [B5] 308 [B14]	305 [B5] 308 [B14]	306 [B5] 304 [B14]	---	---	---

Not binding dimensions and weights

RD 52-53

Gearboxes RD

Dimensions

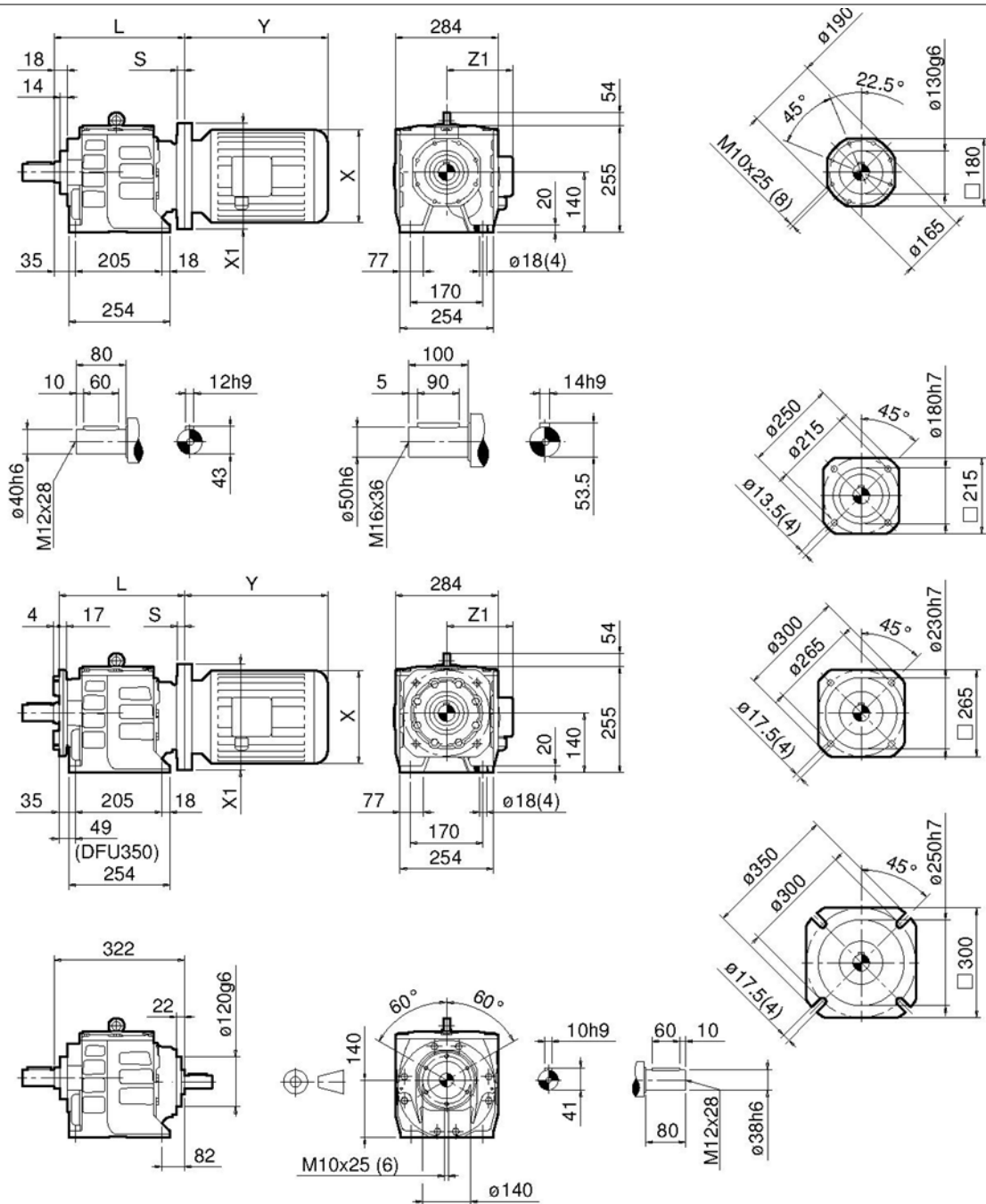

RD	52 / 53	52 / 53	52 / 53	52/53	52/53	52/53	52	52
IEC	80	90 S	90 L	100	112	132 S/M	160	180
X / Y / Z1	Dimensions: page 43							
X1 (B5) / S	200/16	200/16	200/16	250/16	250/16	300/16	350/25	350/25
X1 (B14) / S	---	---	---	---	---	200/16	---	---
L	322	322	322	322	322	322	353	353
L1 / L1(ø350)	322/336	322/336	322/336	322/336	322/336	322/336	353/367	353/367

Not binding dimensions and weights

Dimensions

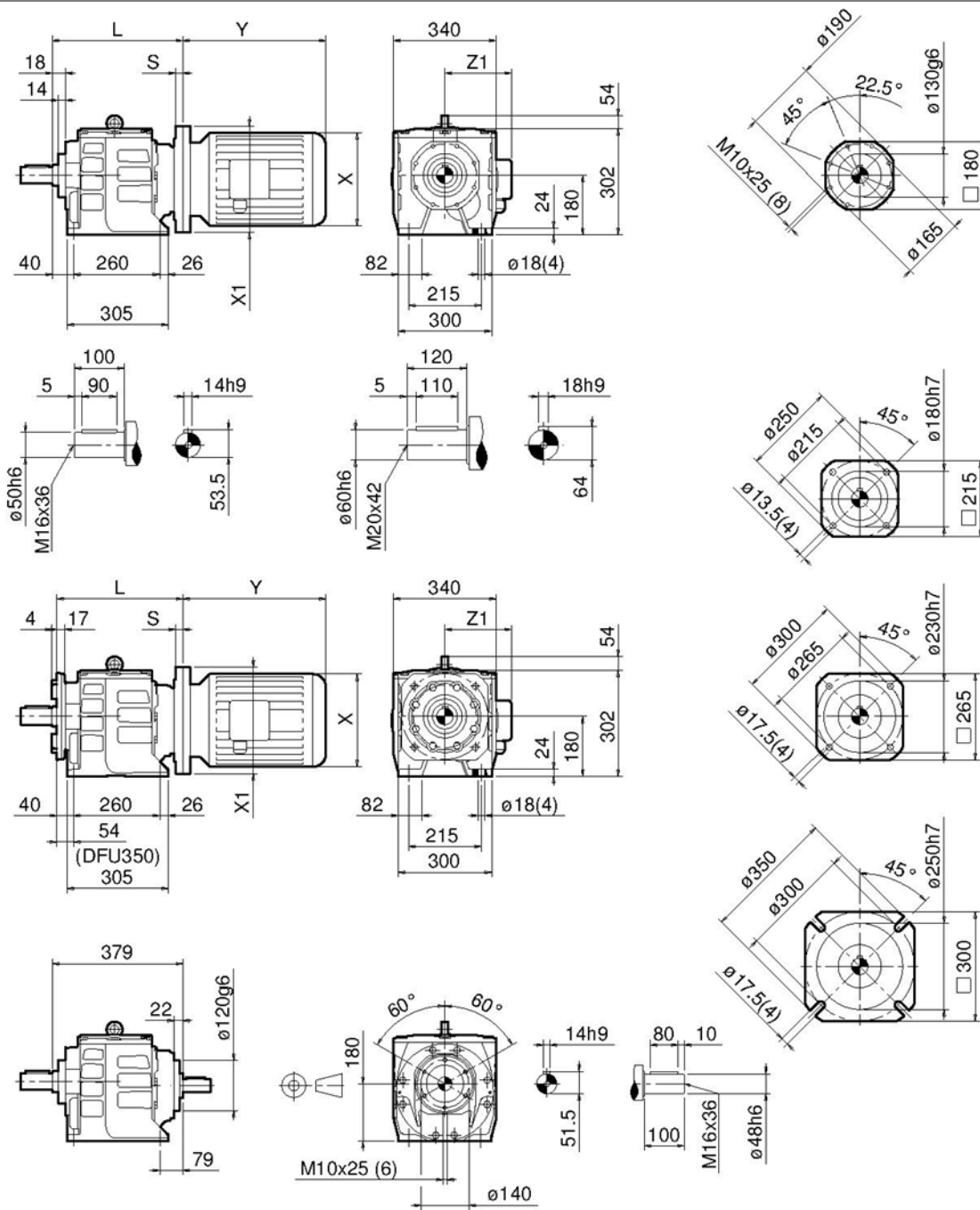

RD	62 / 63	62 / 63	62 / 63	62 / 63	62 / 63	62 / 63	62	62
IEC	80	90 S	90 L	100	112	132 S/M	160	180
X / Y / Z1	Dimensions: page 43							
X1 (B5) / S	200/16	200/16	200/16	250/16	250/16	300/16	350/25	350/25
X1 (B14) / S	---	---	---	---	---	200/16	---	---
L	379	379	379	379	379	379	410	410
L1 / L1(ø350)	379/393	379/393	379/393	379/393	379/393	379/393	410/424	410/424

Not binding dimensions and weights

Gearboxes RD

Rotation and Component Parts

RD2

Two-stage gearbox

- A - Motor flange adapter
- B - 2-stage input cover + T3 gear
- C - Housing + T4, T5, T6 gears
- D - Output flange

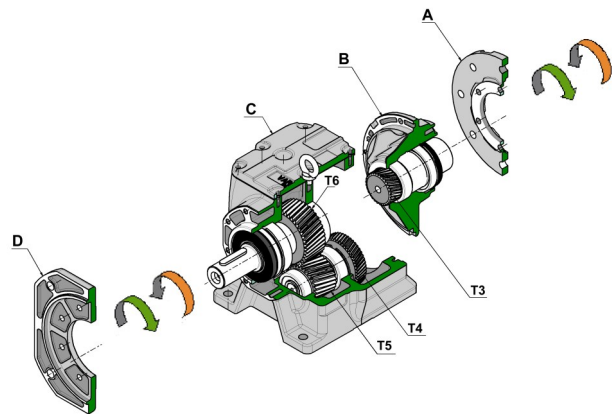

- Input/output rotation

RD3

Three-stage gearbox

- A - Motor flange adapter
- B - 3-stage input cover + T1, T2, T3 gears
- C - Housing + T4, T5, T6 gears
- D - Output flange

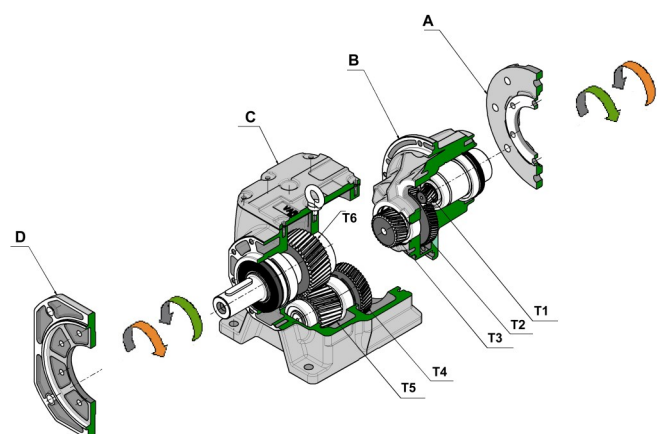

- Input/output rotation

RD Gearboxes

Electric motor Standards

Voltage and frequency

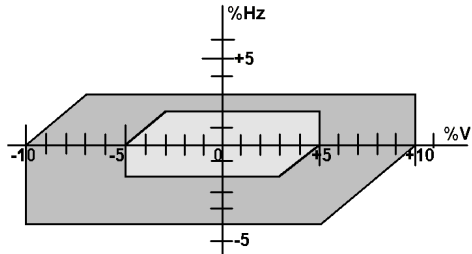

Rated values	Usable values
230/400V 50Hz	240/415V 50Hz 220/380V 50Hz
277/480V 60 Hz	265/460V 60Hz 260/440V 60Hz

- Normal duty
- Heavy duty but limited

Insulation class

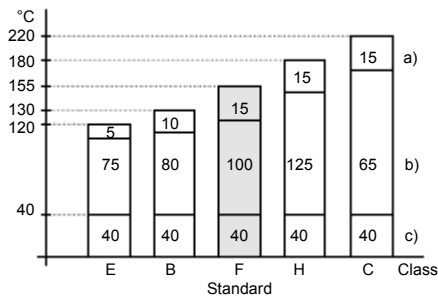

- a) safety margin
- b) admissible temperature
- c) conventional ambient temperature

Altitude and Temperature Factors

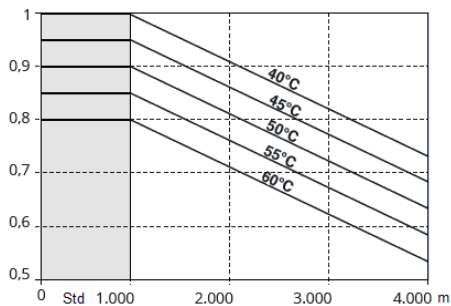

- Conventional conditions
- 1000 m - altitude above sea level [3285 ft]
- 40 °C - ambient temperature [104 °F]
- 15 °C - min. ambient air temperature [5 °F]
- ≤ 60% - relative humidity

Gearboxes RD

European Directive 94/9/EC - ATEX

The European Directive 94/9/EC-ATEX relates not only to electric devices but to all the machines and driving units destined, alone or combined, to operate in potentially explosive environments within European Community territory.

The gearboxes VARVEL-ATEX are manufactured

- with metallic housings and covers, containing the driving gears fitted on ball or roller bearings;
- FKM-Fluor-elastomer (Viton) oil seals on input and output shafts;
- the needed oil quantity to ensure the unit operation;
- sealed thread screws with sealing paste.

The gearboxes VARVEL-ATEX are identified in the Directive as «components», therefore stripped away any autonomous function, but fundamental to operation of units and protection systems destined to production, transport, storage, measuring, adjusting and conversion of energy and material transformation that because of their own inflammable potentiality, risk to induce an explosion trigger.

ATEX-Directive Code Breakdown

- **Group**

utilization in

I - mining

II - surface industries

- **Category**

1- continuous exposure in possibly explosive environment for more than 1000 hrs/year or with frequent malfunctioning

2- occasional exposure in possibly explosive environment for 10 to 1000 hrs/year or with sporadic malfunctioning

3- not very likely exposure in possibly explosive environment and if happened, not longer than 10 hours/year

- **Letters “G” and “D”**

G - gas presence

D - dust presence

- **Letters “c” and “k”**

c - safety indication of construction

k - safety indication of immersion in liquid

- **IP66 (IP4X Nema)**

IP- International Protection Coding

6 - 1st digit - protection dust tight

6 - 2nd digit - protection against powerful water jets

- **T_{max} and T_{amb}**

T_{max} - surface max. temperature

T_{amb} - ambient max. temperature

RD Gearboxes

ATEX - European Directive 94/9/EC

VARVEL RD, RS, RT, RN, RO, RV, RP90 and XA100 series are conforming with design requirements asked by Group II, Category 2 or 3, and for operation in possible hazardous zones in presence of gas (zones 1 and 2) and combustible dust (zones 21 and 22).

The VARVEL-ATEX products are marked

 **II 2 GD ck IP66 CE**
T_{max}=135°C

Group	Category	Gas, Vapours, Cloud	Zone	Dust
I (a)	M1 (c)			
	M2 (d)			
II (b)	1 (c)	G (0)		D (20)
	2 (d)	G (1)		D (21)
	3 (e)	G (2)		D (22)

Warning

The VARVEL-ATEX gearboxes **are not certified** for operation in **shaded areas**.

Key:

- (a) - Mines
- (b) - Surface industries
- (c) - Protection level: very high
- (d) - Protection level: high
- (e) - Protection level: normal
- (0) - Continuous presence of gas
- (1) - Discontinuous presence of gas
- (2) - Occasional presence of gas
- (20) - Continuous presence of dust
- (21) - Discontinuous presence of dust
- (22) - Occasional presence of dust

Gearboxes RD

Declaration of Conformity - ATEX

VARVEL SpA

Via 2 Agosto 1980, 9
I-40053 - Crespellano-
Valsamoggia BO
Italy

dichiara sotto la propria responsabilità che il prodotto

declares on his own responsibility that the product

**Riduttori
Gearboxes**

Serie/s RS
Serie/s RT
 Serie/s RD
Serie/s RC
Serie/s RP
Serie/s XA
Serie/s RN
Serie/s RO-RV

al quale questa dichiarazione si riferisce, è conforme alla Direttiva

to which this declaration relates to, complies with the Directive

2014/34/EU (ATEX).

La conformità è stata verificata sulla base dei requisiti delle norme o dei documenti normativi

The conformity is under observance of the standard documents

**EN 1127-1: 2011
EN 13463-1: 2009
EN 13463-5: 2011
EN 13463-8: 2003**

Modo di protezione:
Type of protection:

**II 2-G D ck
T4 T135°C IP66
Tamb. -20 / +55°C**

I File Tecnici (in accordo all'allegato VIII Direttiva 94/9/CE)

The Technical Files (according with Annex VIII of Directive 94/9/EC)

**ATEX 13RS, ATEX 13RT, ATEX 13RD,
ATEX 13RP, ATEX 13XA, ATEX 13RN,
ATEX 13RO-RV**

sono stati depositati presso l'Organismo Notificato di deposito del fascicolo tecnico

were deposited at the Notified Body of Technical File Deposit

**0080 INERIS,
F-60550 Verneuil en Halatte, France**



Firma autorizzata - *Authorized Signature*

(Funzione - *Function*)

Luogo e data dell'emissione
Place and Date of Issue

Crespellano-Valsamoggia,/..../....

RD Gearboxes

Abstract of OPERATION AND MAINTENANCE INSTRUCTIONS

(complete manual on www.varvel.com)

Under the terms of the Machine Directive 2006/42/EC and relevant Guidelines, the speed gearboxes and variators are considered as "machines' separate elements not having a specific application and meant for being incorporated onto the machine. The complete machine and equipped with such components must comply with the essential and relevant requisites for safety and health preservation" of the mentioned Directive.

Installation

Check if the unit to be installed, is properly selected to perform the required function and that its mounting position complies with the order.

The nameplate reports such information.

Check mounting stability to ensure the unit runs without vibrations or overloads.

Running

The unit may be connected for clockwise or counter-clockwise rotation.

The unit must be stopped as soon as defective running or unexpected noise occur, remove the faulty part or return the unit to the factory for checking.

If the faulty part is not replaced, other parts can also be affected, causing more severe damage and making the identification of initial cause more difficult.

Maintenance

Although the units are no-load run tested in the factory before despatch, it is recommended not to run them at maximum load for the first 20-30 running hours to allow the proper running in.

The gearboxes are delivered already filled with long-life synthetic oil and, in case of replacement or topping, do not mix with mineral lubricants.

Handling

When hoisting, use relevant housing locations or eyebolts if provided, or foot or flange holes.

Never hoist on any moving part.

Painting

Carefully protect oil seals, coupling faces and shafts when units are repainted.

Long-term storage

For storages longer than three months, apply anti-oxidants onto shafts and machined surfaces, and protective grease on oil seal lips.

Product's Environmental Management

In conformity with Environmental Certification ISO 14001, we recommend the following to dispose of our products:

- scraped components of the units to be delivered to authorized centres for metal object collection;
- oils and lubricants drained from the units to be delivered to Exhausted Oil Unions;
- packages (pallets, carton boxes, paper, plastic, etc.) to lead into regeneration/recycling circuits as far as possible, by delivering separate waste classes to authorized companies.